

# Bidding Documents

*for the City of Pembroke's*



## **Westbrooke Circle Drainage Repair Project**

*prepared by*

**MCGHEE ENGINEERING, INC.**  
Guthrie, Kentucky

**October 25, 2019**

# Specifications and Contract Documents

prepared for the

## *City of Pembroke*

### Westbrooke Circle Drainage Repair Project

**Judy Peterson**  
*Mayor*

**Steve Pyle**  
*Councilman*

**Jeanette Aldridge**  
*Councilwoman*

**David Rule**  
*Councilman*

**Betsy Shelton**  
*Councilwoman*

prepared by

**MCGHEE ENGINEERING, INC.**  
202 Ewing Street, P. O. Box 267  
Guthrie, Kentucky 42234  
(270) 483-9985

---

**City of Pembroke**  
**Westbrooke Circle Drainage Repair Project**

**CONTRACT DOCUMENTS**  
**Table of Contents**

		<b><u>Pages</u></b>
<b><u>Bidding Documents</u></b>		
Advertisement for Bids		1
Instructions to Bidders		11
Bid Bond		2
Bid Form		4
List of Subcontractors		1
Statement of Experience		1
 <b><u>Agreement Section</u></b>		
Notice of Award		1
Agreement		1
Performance Bond		3
Payment Bond		3
Power of Attorney	(Provided by Contractor)	-
Certificate of Insurance	(Provided by Contractor)	-
Notice to Proceed		1
 <b><u>Conditions Section</u></b>		
General Conditions		16
Contract Change Order		1
Supplemental General Conditions		3
 <b><u>Technical Specifications</u></b>		
01-100	Summary of Work	4
03-100	Concrete Formwork	4
03-210	Reinforcing Steel	2
 <b><u>Construction Plans</u></b>		
Contract Drawings consist of three (3) sheets.		

## ADVERTISEMENT TO BID

The **City of Pembroke** will receive separate, sealed Bids for their **Westbrook Circle Drainage Repair Project** until **11:00 a.m. local time, Tuesday, November 26, 2019** at the Pembroke City Hall, 222 S Main St, Pembroke, Kentucky, 42266, at which time they will be publicly opened and read aloud.

The Contract involves the replacement of two drainage grates and surrounding concrete along Westbrooke Circle in Pembroke, Kentucky. Bids are to be addressed to the City of Pembroke, P.O. Box 162, Pembroke, KY 42266, and shall be marked "**Sealed Bid – Drainage Repair Project.**" Bids are also to include on the outside, Bidder's name and address and the Bid receipt date and time. Bids shall be prepared in compliance with the requirements of the Instructions to Bidders.

The Issuing Office for the Bidding Documents is: McGhee Engineering, Inc., at P.O. Box 267, 202 South Ewing Street, Guthrie, Kentucky 42234 or by calling (270) 483-9985. Perspective Bidders may examine the Bidding Documents at the Issuing Office on Mondays through Fridays between the hours of 8:30-4:30 pm, and may obtain copies of the Bidding Documents from the Issuing Office as described below.

Plans must be ordered by visiting [www.mcgheengineering.com](http://www.mcgheengineering.com) and clicking "**Bid Opportunities**". Plans will be sold with an option of Digital only OR Printed Set w/ Digital copy. Bids will be accepted only from registered contractors holding approved bid forms provided by the Issuing Office. Plan holders may be viewed at [www.mcgheengineering.com](http://www.mcgheengineering.com).

No Bid will be considered unless accompanied by a cashier's, certified or bank check or a Bid Bond equal to at least five percent of the maximum Bid, payable to the OWNER as a guarantee that after a Bid is accepted. Bidder will execute and file the Agreement and 100% Performance and Payment Bonds within fifteen days after the tentative Notice of Award. Contract award shall be made based on the lowest, responsive, responsible Bid. The City of Pembroke reserves the right to reject any or all Bids, to waive any technicality, and to accept any Bid which it deems advantageous. All Bids shall remain subject to acceptance for 90 days after the time set for opening Bids. The City of Pembroke is an equal opportunity employer and encourages minority and small businesses to bid on all projects.

All taxes, fees, and licenses are the responsibility of the successful Bidder unless specifically exempted in the Bidding Documents.

Published by the authority of the:     City of Pembroke  
   Judy Peterson, Mayor

Dated: November 5, 2019

*"EQUAL EMPLOYMENT OPPORTUNITY"*

## **INSTRUCTIONS TO BIDDERS**

A. These Instructions to Bidders establish requirements for Bidding and Award of Contract.

B. Table of Contents

1. Defined Terms
2. Copies of Bidding Documents
3. Qualifications of Bidders
4. Examination of Bidding Documents, Other Related Data and Site
5. Prebid Conference
6. Site and Other Areas
7. Interpretations and Addenda
8. Bid Security
9. Contract Times
10. Liquidated Damages
11. Substitute or "Or-Equal" Items
12. Subcontractors, Suppliers, and Others
13. Bid
14. Basis of Bid; Evaluation of Bids
15. Submission of Bids
16. Modification and Withdrawal of Bids
17. Opening of Bids
18. Bids to Remain Subject to Acceptance
19. Award of Contract
20. Contract Security and Insurance
21. Signing of Agreement
22. Retainage
23. Performance Bond Wages
24. Licenses, Fees, and Taxes
25. Wage Rate Determination
26. Kickback Statutes
27. Other Bid Requirements
28. Laws, Ordinances, and Regulations
29. Insurance
30. Safety Standards and Accident Prevention

### ARTICLE 1- DEFINED TERMS

Other terms used in the bidding documents and not defined elsewhere have the following meanings which are applicable to both the singular and plural thereof.

1.01 Terms used in these Instructions to Bidders will have the meanings indicated in the General Conditions and the Supplementary Conditions. Additional terms used in these Instructions to Bidders have the meanings indicated below which are applicable to both the singular and plural thereof.

- A. Bidder - The individual or entity who submits a Bid directly to OWNER.
- B. Issuing Office - The office from which the Bidding Documents are to be issued and where the bidding procedures are to be administered.
- C. Successful Bidder - The lowest responsible Bidder submitting a responsive Bid to whom OWNER (on the basis of OWNER's evaluation as hereinafter provided) makes an award.

## ARTICLE 2 - COPIES OF BIDDING DOCUMENTS

2.01 Complete sets of the Bidding Documents in the number and for the non-refundable sum, if any, stated in the Advertisement to Bid may be obtained from the Issuing Office.

2.02 Complete sets of Bidding Documents must be used in preparing Bids; neither OWNER nor ENGINEER assume any responsibility for errors or misinterpretations resulting from the use of incomplete sets of Bidding Documents.

2.03 OWNER and ENGINEER in making copies of Bidding Documents available on the above terms do so only for the purpose of obtaining Bids for the Work and do not confer a license or grant for any other use.

## ARTICLE 3 - QUALIFICATIONS OF BIDDERS

3.01 A formal pre-bid qualification of Bidders will not be required for the Project. However, one or more bidders may be asked to complete a reference statement in order to document the bidder's past performance on similar projects. The Owner reserves the right to contact references and to use the information received in assessing the bidder's qualifications to perform the work. Bidders may be asked to submit written evidence such as financial data, previous experience, present commitments and other such data as may be called for below. Bidder must be prepared to submit evidence of Bidder's qualifications to do business in the state where the project is located prior to award of the Contract.

## ARTICLE 4 - EXAMINATION OF BIDDING DOCUMENTS, OTHER RELATED DATA AND SITE

### 4.01 Subsurface and Physical Conditions

#### A. The Supplementary Conditions identify:

1. Those reports, if any, of explorations and tests of subsurface conditions at or contiguous to the Site that ENGINEER has used in preparing the Bidding Documents.

2. Those drawings of physical conditions in or relating to existing surface and subsurface structures at or contiguous to the Site (except underground Facilities) that ENGINEER has used in preparing the Bidding Documents.

B. Copies of reports, if applicable, and drawings referenced in paragraph 4.01.A are attached within the Contract Documents, and the "technical data" contained therein upon which Bidder is entitled to rely as provided in paragraph 4.02 of the General Conditions has been identified and established in paragraph 4.02 of the Supplementary Conditions. Bidder is responsible for any interpretation or conclusion Bidder draws from any "technical data" or any other data, interpretations, opinions, or information contained in such reports or shown or indicated in such drawings.

### 4.02 Underground Facilities

A. Information and data shown or indicated in the Bidding Documents with respect to existing Underground Facilities at or contiguous to the Site are based upon information and data furnished to OWNER and ENGINEER by owners of such Underground Facilities, including OWNER or others.

#### 4.03 Hazardous Environmental Condition

A. The Supplementary Conditions identify those reports and drawings relating to a Hazardous Environmental Condition identified at the Site, if any, that ENGINEER has used in preparing the Bidding Documents.

B. Copies of reports, if applicable, and drawings referenced in paragraph 4.03.A will be made available by OWNER to any Bidder on request. Those reports and drawings are not part of the Contract Documents, but the “technical data” contained therein upon which Bidder is entitled to rely as provided in paragraph 4.06 of the General Conditions has been identified and established in paragraph 4.06 of the Supplementary Conditions. Bidder is responsible for any interpretation or conclusion Bidder draws from any “technical data” or any other data, interpretations, opinions, or information contained in such reports or shown or indicated in such drawings.

4.04 Provisions concerning responsibilities for the adequacy of data furnished to prospective Bidders with respect to subsurface conditions, other physical conditions and Underground Facilities, and possible changes in the Bidding Documents due to differing or unanticipated conditions appear in paragraphs 4.02, 4.03, and 4.04 of the General Conditions. Provisions concerning responsibilities for the adequacy of data furnished to prospective Bidders with respect to a Hazardous Environmental Condition at the Site, if any, and possible changes in the Contract Documents because of any Hazardous Environmental Condition uncovered or revealed at the Site which was not shown or indicated in the Drawings or Specifications or identified in the Contract Documents to be within the scope of the Work appear in paragraph 4.06 of the General Conditions.

4.05 On request, OWNER will provide Bidder access to the Site to conduct such examinations, investigations, explorations, tests, and studies as Bidder deems necessary for submission of a Bid. Bidder shall fill all holes and clean up and restore the Site to its former condition upon completion of such explorations, investigations, tests, and studies.

4.06 Reference is made to Article 7 of the Supplementary Conditions for the identification of the general nature of other work, if applicable, that is to be performed at the Site by OWNER or others (such as utilities and other prime contractors) that relates to the Work for which a Bid is to be submitted. On request, OWNER will provide to each Bidder for examination access to or copies of Contract Documents (other than portions thereof related to price) for such other work.

4.07 It is the responsibility of each Bidder before submitting a Bid to:

A. Examine and carefully study the Bidding Documents, including any Addenda and the other related data identified in the Bidding Documents;

B. Visit the Site and become familiar with and satisfy Bidder as to the general, local, and Site conditions that may affect cost, progress, and performance of the Work;

C. Become familiar with and satisfy Bidder as to all federal, state, and local Laws and Regulations that may affect cost, progress, or performance of the Work;

D. Carefully study all reports of explorations and tests of subsurface conditions at or contiguous to the Site and all drawings of physical conditions in or relating to existing surface or subsurface structures at or contiguous to the Site (except Underground Facilities) which have been identified in the Supplementary conditions as provided in paragraph 4.02 of the General Conditions, and carefully study all reports and drawings of a Hazardous Environmental Condition, if any, at the Site which have been identified in the Supplementary Conditions as provided in paragraph 4.06 of the General Conditions;

E. Obtain and carefully study (or assume responsibility for doing so) all additional or supplementary examinations, investigations, explorations, tests, studies, and data concerning conditions (surface, subsurface, and Underground Facilities) at or contiguous to the Site which may affect cost, progress, or performance of the Work or which relate to any aspect of the means, methods, techniques, sequences, and procedures of construction to be employed by Bidder, including any specific means, methods, techniques, sequences, and procedures of construction expressly required by the Bidding Documents, and safety precautions and programs incident thereto (Bidder may want to engage the services of a specialist or specialists to help Bidder evaluate these physical conditions and their impact on the work enumerated above);

F. Agree at the time of submitting its Bid that no further examinations, investigations, explorations, tests, studies, or data are necessary for the determination of its Bid for performance of the Work at the price bid and within the times and in accordance with the other terms and conditions of the Bidding Documents;

G. Become aware of the general nature of the work to be performed by OWNER and others at the Site that relates to the Work as indicated in the Bidding Documents;

H. Correlate the information known to Bidder, information and observations obtained from visits to the Site, reports and drawings identified in the Bidding Documents, and all additional examinations, investigations, explorations, tests, studies, and data with the Bidding Documents;

I. Promptly give ENGINEER written notice of all conflicts, errors, ambiguities, or discrepancies that Bidder discovers in the Bidding documents and confirm that the written resolution thereof by ENGINEER is acceptable to Bidder; and

J. Determine that the Bidding Documents are generally sufficient to indicate and convey understanding of all terms and conditions for the performance of the Work.

4.08 The submission of a Bid will constitute an incontrovertible representation by Bidder that Bidder has complied with every requirement of this Article 4, that without exception the Bid is premised upon performing and furnishing the work required by the Bidding Documents and applying the specific means, methods, techniques, sequences, or procedures of construction (if any) that may be shown or indicated or expressly required by the Bidding Documents, that Bidder has given ENGINEER written notice of all conflicts, errors, ambiguities, and discrepancies that Bidder has discovered in the Bidding Documents and the written resolution thereof by ENGINEER is acceptable to Bidder, and that the Bidding Documents are generally sufficient to indicate and convey understanding of all terms and conditions for performing and furnishing the work.

#### ARTICLE 5 - PRE-BID CONFERENCE

5.01 A pre-Bid conference is not scheduled. If one is warranted, an addendum will be issued to indicate a time and location.

#### ARTICLE 6 - SITE AND OTHER AREAS

6.01 The Site is identified in the Bidding Documents. All additional lands and access thereto required for temporary construction facilities, construction equipment, or storage of materials and equipment are to be obtained and paid for by CONTRACTOR. Easements for permanent structures or permanent changes in existing facilities are to be obtained and paid for by OWNER unless otherwise provided in the Bidding Documents.



## ARTICLE 7 - INTERPRETATIONS AND ADDENDA

7.01 All questions about the meaning or intent of the Bidding Documents are to be submitted to ENGINEER in writing. Interpretations or clarifications considered necessary by ENGINEER in response to such questions will be issued by Addenda mailed or delivered to all parties recorded by Issuing Office as having received the Bidding Documents.

7.02 All requests for interpretation must be received at least **four days** prior to the day set for receiving Bids. Addenda will be mailed no later than **three days** prior to the day set for receiving Bids. Failure of any Bidder to receive any such Addendum or interpretation shall not relieve such Bidder from any obligations under the Bid as submitted. All Addenda so issued shall become part of the Contract Documents.

7.03 Only questions answered by Addenda will be binding. Oral and other interpretations or clarifications will be without legal effect.

7.04 Addenda may also be issued to clarify, correct, or change the Bidding Documents as deemed advisable by OWNER or ENGINEER.

7.05 Receipt of all addenda must be acknowledged in space provided in the Bid.

## ARTICLE 8 - BID SECURITY

8.01 A Bid must be accompanied by Bid security made payable to OWNER in an amount of **five percent (5%)** of the Bidder's maximum Bid price and in the form of a certified check or a Bid Bond (EJCDC No. C-430, 2002 Edition) issued by a surety meeting the requirements of paragraphs 5.01 and 5.02 of the General Conditions.

8.02 The Bid security of the successful Bidder will be retained until such Bidder has executed the Contract Documents, furnished the required Contract security, and met the other conditions of the Notice of Award, whereupon the Bid security will be returned upon request. If the Successful Bidder fails to execute and deliver the Contract Documents and furnish the required Contract security within ten (10) days after the Notice of Award, OWNER may annul the Notice of Award and the Bid security of the Bidder will be forfeited. The Bid security of other Bidders whom OWNER believes to have a reasonable chance of receiving the award may be retained by OWNER until the earlier of seven days after the Effective Date of the Agreement or 91 days after the Bid opening, whereupon Bid security furnished by such Bidders will be returned.

8.03 Bid security of other Bidders whom OWNER believes do not have a reasonable chance of receiving the award will be returned, upon request, within seven days after the Bid opening.

## ARTICLE 9 - CONTRACT TIMES

9.01 The project as indicated in the Plans and Specifications shall be completed within the number of consecutive working days stated in the Contract unless the period for completion is extended otherwise by the CONTRACT DOCUMENTS. Contractors shall submit any request for time extensions at the time of submission of the pay request covering the period during which the time extension is requested, and such requests shall include justification in conformance with the Contract. Failure to make timely submittal of requests for time extension shall be grounds for their denial. The times set forth in the Agreement for completion of work are an essential element of the Contract.

## ARTICLE 10 - LIQUIDATED DAMAGES

10.01 The Contractor and Owner understand and agree that a breach of this Contract as to completion on

time will cause damage to the Owner. The Owner will be harmed and damages will be due from the Contractor should the work not be completed on time. The parties agree that for each and every calendar day the work or any portion thereof shall remain uncompleted after the expiration of the contract time limit, **two hundred fifty dollars (\$250.00) per day** will be deducted from the money due or to become due the Contractor, not as a penalty, but as liquidated damages and added expense of engineering and overhead.

#### ARTICLE 11 - SUBSTITUTE OR "OR-EQUAL" ITEMS

11.01 The material manufacturers listed in the specifications have been specified because of their products' quality and suitability to this project. The bidder may request that additional manufacturers' products be approved for use on the project by submitting to the Engineer, in writing, his request accompanied by complete descriptive materials on the proposed alternate product. The Engineer must receive this request no later than **four days** prior to the deadline for submittal of bids. Those products, which the Engineer deems equal to those already named in the specifications will be named in an addendum, sent to all bidders. Only those products named in the specifications or in subsequent addenda will be acceptable for use on the job. The procedure for submission of any such application by CONTRACTOR and consideration by ENGINEER is set forth in paragraph 6.05.A of the General Conditions and may be supplemented in the General Requirements.

11.02 As an exception to the above, there will be no substitutions or "or equal" items considered for Base Bid or Alternative Bid designated items that are included in the Contract award.

#### ARTICLE 12 - SUBCONTRACTORS, SUPPLIERS, AND OTHERS

12.01 A list of subcontractors, suppliers, individuals, or entities shall be submitted along with the Bid at the Bid Opening to the OWNER. An experience statement of each Bidder shall accompany such list with pertinent information regarding similar projects and other evidence of qualifications for each such subcontractor, supplier, individuals, or entities if requested by OWNER. If OWNER or ENGINEER, after due investigation, has reasonable objection to any proposed subcontractor, supplier, individual, or entity may, before the Notice of Award is given, request the apparent successful Bidder to submit an acceptable substitute without an increase in the Bid.

12.02 If apparent successful Bidder declines to make any such substitution, OWNER may award the Contract to the next lowest Bidder that proposes to use acceptable subcontractors, suppliers, individuals, or entities. Declining to make requested substitutions will not constitute grounds for the forfeiture of the Bid security of any Bidder. Any subcontractor, supplier, individual, or entity listed and against which OWNER or ENGINEER makes no written objection prior to the giving of the Notice of Award will be deemed acceptable to OWNER and ENGINEER subject to revocation of such acceptance after the Effective Date of the Agreement as provided in paragraph 6.06.B of the General Conditions.

12.03 CONTRACTOR shall not be required to employ any subcontractor, supplier, individual, or entity against whom CONTRACTOR has reasonable objection.

#### ARTICLE 13 - BID

13.01 The Bid Form is included with the Bidding Documents.

13.02 All blanks on the Bid form must be completed in ink or typewritten and the Bid signed, and no changes shall be made in the phraseology of the forms or of the items mentioned therein. A Bid price shall be indicated for each section, Bid item, alternative, adjustment unit price item or unit price item listed therein, or the words "No Bid," "No Change," or "Not Applicable" entered. Any bid may be deemed irregular which contains any omission, erasure, alteration, addition, irregularity of any kind, or item not called

for, or in which does not contain prices set opposite each of the several items in the Proposal form, or in which any of the prices are obviously unbalanced.

13.03 A Bid by a corporation shall be executed in the corporate name by the president or vice president or other corporate officer accompanied by evidence of authority to sign. The corporate seal shall be affixed and attested by the secretary or an assistant secretary. The corporate address and state of incorporation shall be shown below the signature.

13.04 A Bid by a partnership shall be executed in the partnership name and signed by a partner (whose title must appear under the signature), accompanied by evidence of authority to sign. The official address of the partnership shall be shown below the signature.

13.05 A Bid by a limited liability company shall be executed in the name of the firm by a member and accompanied by evidence of authority to sign. The state of formation of the firm and the official address of the firm shall be shown below the signature.

13.06 A Bid by an individual shall show the Bidder's name and official address.

13.07 A Bid by a joint venture shall be executed by each joint venturer in the manner indicated on the Bid form. The official address of the joint venture shall be shown below the signature.

13.08 All names shall be printed in ink below the signatures.

13.09 The Bid shall contain an acknowledgment of receipt of all Addenda, the numbers of which must be filled in on the Bid form.

13.10 The address and telephone number for communications regarding the Bid shall be shown.

13.11 The Bid shall contain evidence of Bidder's authority and qualification to do business in the state where the Project is located or covenant to obtain such qualification prior to award of the Contract.

#### ARTICLE 14 - BASIS OF BID; COMPARISON OF BIDS

14.01 Bidders shall submit a Bid on a lump sum price basis for the Work on the Bid Form.

14.02 Bidders shall complete and submit with the Bid all such items as are identified as being part of the bid submittal.

14.03 Discrepancies between the price written in figures and price written in words will be resolved in favor of the price written in words.

14.04 Bids will be evaluated on the basis of price, and on the responsiveness and qualifications of the Bidder. Life-cycle cost analysis and the effect of time of completion on the overall project may be considered to determine the lowest overall cost to the entire water system. It shall be at the Owner's sole discretion to determine which bid, if any, is most cost effective considering price and time of completion in relation to the total water system project.

#### ARTICLE 15 - SUBMISSION OF BIDS

15.01 Bid Form is to be completed and submitted with all the attachments as required.

15.02 A Bid shall be submitted no later than the date and time prescribed and at the place indicated in the Advertisement to Bid and shall be enclosed in an opaque sealed envelope, marked with the Project title (and, if applicable, the designated portion of the Project for which the Bid is submitted), the name

and address of the Bidder, and shall be accompanied by the Bid security and other required documents. If the Bid is sent by mail or other delivery system, the sealed envelope containing the Bid shall be enclosed in a separate envelope plainly marked on the outside with the notation "BID ENCLOSED." A mailed Bid shall be addressed to place indicated in the Advertisement to Bid. No relief shall be provided for a mailed Bid not being received by the prescribed time. No Bid will be considered which is received after the time set for receiving Bids.

#### ARTICLE 16 - MODIFICATION AND WITHDRAWAL OF BIDS

16.01 A Bid may be modified or withdrawn by an appropriate document duly executed in the manner that a Bid must be executed and delivered to the place where Bids are to be submitted prior to the date and time for the opening of Bids.

16.02 If within 24 hours after Bids are opened any Bidder files a duly signed written notice with Owner and promptly thereafter demonstrates to the reasonable satisfaction of Owner that there was a material and substantial mistake in the preparation of its Bid, that Bidder may withdraw its Bid, and the Bid security will be returned. Thereafter, if the Work is rebid or negotiated, that Bidder will be disqualified from further bidding on the Work. This provision to withdraw a Bid without forfeiting the Bid security does not apply to Bidder's errors in judgment in preparing the Bid.

#### ARTICLE 17 - OPENING OF BIDS

17.01 Bids will be opened at the time and place indicated in the Advertisement to Bid and, (unless obviously nonresponsive), read aloud publicly. An abstract of the amounts of the base Bids and major alternatives and components (if any) will be made available to Bidders after the opening of Bids.

#### ARTICLE 18 - BIDS TO REMAIN SUBJECT TO ACCEPTANCE

18.01 All Bids will remain subject to acceptance for a period of **90 days**, but OWNER may, in its sole discretion, release any Bid and return the Bid security prior to the end of this period.

#### ARTICLE 19 - AWARD OF CONTRACT

19.01 It is the intent of the OWNER to award a contract. However, the OWNER reserves without limitation the right to reject any or all Bids, to waive any and all informalities not involving price, time or changes in the work and to negotiate Contract terms with the successful Bidder; and the right to accept or reject all incomplete, nonconforming, nonresponsive, unbalanced, obscure, or conditional Bids, or Bids which contain additions not called for, erasures, alterations, or irregularities of any kind, or which do not comply with the Instructions to Bidders. OWNER reserves the right to reject the Bid of any Bidder if OWNER believes that it would not be in the best interest of the project to make an award to that Bidder, whether because the Bid is not responsive or the Bidder is unqualified or of doubtful financial ability or fails to meet any other pertinent standard or criteria established by OWNER. OWNER further reserves the right to reject the Bid of any Bidder whom it finds, after reasonable inquiry and evaluation, to be nonresponsive.

19.02 More than one Bid for the same Work from an individual or entity under the same or different names will not be considered. Reasonable grounds for believing that any Bidder has an interest in more than one Bid for the Work may be cause for disqualification of that Bidder and the rejection of all Bids in which that Bidder has an interest.

19.03 In evaluating Bids, OWNER will consider the qualifications of the Bidders, whether or not the Bids comply with the prescribed requirements, and such alternatives, unit prices, and other data as may be requested in the Bid form or prior to the Notice of Award.

19.04 In evaluating Bids, OWNER will consider the qualifications of Bidders and may consider the qualifications and experience of subcontractors, suppliers, and other individuals or entities proposed for those portions of the work for which the identity of subcontractors, suppliers, and other individuals or entities must be submitted as provided in the Supplementary Conditions.

19.05 OWNER may make such investigations as OWNER deems necessary to assist in the evaluation of any Bid and to establish the responsibility, qualifications, and financial ability of Bidders, proposed subcontractors, suppliers, and other persons and organizations to perform and furnish the work in accordance with the Contract Documents to OWNER's satisfaction within the prescribed time. Bidder shall furnish to OWNER all such information and data for this purpose as OWNER may request. OWNER reserves the right to reject any Bid if the evidence submitted by, or investigation of, such Bidder fails to satisfy OWNER that such Bidder is properly qualified to carry out the obligations of the Contract Documents and to complete the work contemplated therein.

19.06 OWNER shall be satisfied that Bidder involved (1) maintains a permanent place of business, (2) has adequate plant and equipment to do the work properly and expeditiously, (3) has a suitable financial status to meet obligations incident to the work, (4) has appropriate technical experience, and (5) can submit a satisfactory performance record.

19.07 If a Contract is to be awarded, OWNER will give the successful Bidder a Notice of Award within **90 days** after the time set for opening Bids.

#### ARTICLE 20 - CONTRACT SECURITY AND INSURANCE

20.01 Article 5 of the General Conditions, as may be modified by the Supplementary Conditions, sets forth OWNER's requirements as to performance and payment bonds and insurances. When the Successful Bidder delivers the executed Agreement to OWNER, it must be accompanied by the required performance and payment bonds and insurances.

#### ARTICLE 21 - SIGNING OF AGREEMENT

21.01 When the OWNER gives a Tentative Notice of Award to the Successful Bidder, it will be accompanied by a list of items and information required of the Successful Bidder for evaluation by the OWNER and funding agency, if applicable. Within **15** days thereafter, the successful Bidder shall deliver the full number of original copies of the items listed. After the acceptable review and evaluation of all the necessary submittals is complete by the OWNER and funding agency, if applicable, a final Notice of Award, as included in the specifications, will be sent by the OWNER and it must be acknowledged by the Successful Bidder within **10** days thereafter. After receipt of an acknowledged Notice of Award, a pre-construction meeting will be scheduled at which time the OWNER and Successful Bidder will execute the required number of Agreements and Notice to Proceed. After certification by the Local Counsel and any other required parties, the OWNER shall deliver one fully signed counterpart to the Successful Bidder along with a complete set of Drawings with appropriate identification. OWNER will furnish the Contractor three (3) sets of conforming Contract Documents, Technical Specifications and Plans free of charge. Additional sets may be obtained from the Engineer at commercial reproduction rates. The successful bidder shall commence work within ten (10) calendar days after receipt of written notice to proceed and shall progress therewith so that the work shall be completed in accordance with the terms of the Contract Documents within the time allowed after the date of the commencement of contract time.

#### ARTICLE 22 - RETAINAGE

22.01 Prior to Substantial Completion, OWNER will retain an amount equal to 10% of each progress payment application. After 50% of the Work has been completed, the percent retained may be lowered at the discretion of the OWNER and ENGINEER if the job is proceeding satisfactorily. Amounts

previously retained shall not be paid to the CONTRACTOR until substantial completion of the Work. In no event shall the total Retainage be more than 10% of the value of the work satisfactorily completed.

#### ARTICLE 23 – PERFORMANCE BOND FOR WAGE RATES

23.01 Bidders, whether a corporation, partnership, or individual, who have not been doing business in the State of Kentucky for five consecutive years, shall comply with KRS 337.200.

#### ARTICLE 24 – LICENSES, FEES, AND TAXES

24.01 The Bid shall include all taxes in effect at the time the Bid is submitted, unless specifically exempted in the Bidding Documents. No change will be allowed for taxes from which OWNER is exempt. Bidders who are uncertain as to what items are subject to tax, or who require further explanation or clarification, are requested to contact the State of Kentucky Revenue Cabinet.

24.02 Successful Bidder must comply with any City ordinances relating to Occupational License Fees, Business Licenses, payroll, and net profits taxes and any other ordinances which may apply to the project. Refer to the Supplementary Conditions SC-6.10 for additional information.

24.03 Successful Bidder must provide proof of having all such licenses or fees at or before the signing of the Contract.

#### ARTICLE 25 - WAGE RATE DETERMINATION

24.01 Federal and/or State Wage Rates are not applicable to the project.

#### ARTICLE 26 – KICKBACK STATUTES

26.01 Bidders shall comply with Kentucky Statute KRS 45A.455 Prohibitions Against Conflicts of Interests, Gratuities, and Kickbacks.

#### ARTICLE 27 – OTHER BID REQUIREMENTS

27.01 Bidder shall complete the following documents attached to the Bid.

Bid Bond  
Statement of Experience

#### ARTICLE 28 – LAWS, ORDINANCES, AND REGULATIONS

28.01 Bidder must familiarize itself with all laws, ordinances, and regulations by federal, state, city, or other governmental agency, which by reason of being neglected or violated may affect the Work contemplated and must secure and pay the fee required for any permits which may be necessary unless such fees are otherwise indicated to be paid in the Bidding Documents.

#### ARTICLE 29 – INSURANCE

29.01 Before execution of Contract by OWNER, the successful Bidder shall furnish OWNER a certificate or certificates issued by or on behalf of insurers or a self-insurance program or group self insurance program, qualified to do business in the Commonwealth of Kentucky under KRS Chapter 304 or KRS Chapter 342, certifying that the successful Bidder complies with the Worker's Compensation laws of Kentucky and is insured or indemnified against public liability claims which may arise out of the performance of the Work under the proposed Contract.

Bidder shall abide by the requirements under Executive Order No. 11246, as amended, including specifically the provisions of the Equal Opportunity Clause set forth in the General Conditions.

**ARTICLE 30 – SAFETY STANDARDS AND ACCIDENT PREVENTION:**

31.01 With respect to all work performed under this contract, the contractor shall:

1. Comply with the safety standards provision of applicable laws, building and construction codes and the “Manual of Accident Prevention in Construction” published by the Associated General Contractors of America, the requirements of the Occupational Safety and Health Act of 1970 (Public Law 91-596), and the requirements of Title 29 of the Code of Federal Regulations, Section 1518 as published in the “federal Register”, Volume 36, No. 75, Saturday, April 17, 1971.
2. Exercise every precaution at all times for the prevention of accidents and the protection of persons (including employees) and property.
3. Maintain at his/her office or other well know place at the job site, all articles necessary for giving first aid to the injured, and shall make standing arrangements for the immediate removal to a hospital or a doctor’s care of persons (including employees), who may be injured on the job site before the employer has made a standing arrangement for removal of injured persons to a hospital or a doctor’s care.

**BID BOND**

Any singular reference to Bidder, Surety, Owner or other party shall be considered plural where applicable.

BIDDER *(Name and Address):*

SURETY *(Name and Address of Principal Place of Business):*

OWNER *(Name and Address):*

**City of Pembroke  
222 S Main St  
P.O. Box 162  
Pembroke, Kentucky 42266**

BID

Bid Due Date:  
Description *(Project Name and Include Location):*

BOND

Bond Number:  
Date *(Not earlier than Bid due date):*  
Penal sum \_\_\_\_\_

(Words)

\$

\_\_\_\_\_ (Figures)

Surety and Bidder, intending to be legally bound hereby, subject to the terms set forth below, do each cause this Bid Bond to be duly executed by an authorized officer, agent, or representative.

**BIDDER**

**SURETY**

(Seal)

(Seal)

\_\_\_\_\_  
Bidder's Name and Corporate Seal

\_\_\_\_\_  
Surety's Name and Corporate Seal

By:

\_\_\_\_\_  
Signature

By:

\_\_\_\_\_  
Signature (Attach Power of Attorney)

\_\_\_\_\_  
Print Name

\_\_\_\_\_  
Print Name

\_\_\_\_\_  
Title

\_\_\_\_\_  
Title

Attest:

\_\_\_\_\_  
Signature

Attest:

\_\_\_\_\_  
Signature

\_\_\_\_\_  
Title

\_\_\_\_\_  
Title

*Note: Above addresses are to be used for giving any required notice. Provide execution by any additional parties, such as joint venturers, if necessary.*



## PENAL SUM FORM

1. Bidder and Surety, jointly and severally, bind themselves, their heirs, executors, administrators, successors, and assigns to pay to Owner upon default of Bidder the penal sum set forth on the face of this Bond. Payment of the penal sum is the extent of Bidder's and Surety's liability. Recovery of such penal sum under the terms of this Bond shall be Owner's sole and exclusive remedy upon default of Bidder.
2. Default of Bidder shall occur upon the failure of Bidder to deliver within the time required by the Bidding Documents (or any extension thereof agreed to in writing by Owner) the executed Agreement required by the Bidding Documents and any performance and payment bonds required by the Bidding Documents.
3. This obligation shall be null and void if:
  - 3.1 Owner accepts Bidder's Bid and Bidder delivers within the time required by the Bidding Documents (or any extension thereof agreed to in writing by Owner) the executed Agreement required by the Bidding Documents and any performance and payment bonds required by the Bidding Documents, or
  - 3.2 All Bids are rejected by Owner, or
  - 3.3 Owner fails to issue a Notice of Award to Bidder within the time specified in the Bidding Documents (or any extension thereof agreed to in writing by Bidder and, if applicable, consented to by Surety when required by Paragraph 5 hereof).
4. Payment under this Bond will be due and payable upon default of Bidder and within 30 calendar days after receipt by Bidder and Surety of written notice of default from Owner, which notice will be given with reasonable promptness, identifying this Bond and the Project and including a statement of the amount due.
5. Surety waives notice of any and all defenses based on or arising out of any time extension to issue Notice of Award agreed to in writing by Owner and Bidder, provided that the total time for issuing Notice of Award including extensions shall not in the aggregate exceed 120 days from Bid due date without Surety's written consent.
6. No suit or action shall be commenced under this Bond prior to 30 calendar days after the notice of default required in Paragraph 4 above is received by Bidder and Surety and in no case later than one year after Bid due date.
7. Any suit or action under this Bond shall be commenced only in a court of competent jurisdiction located in the state in which the Project is located.
8. Notices required hereunder shall be in writing and sent to Bidder and Surety at their respective addresses shown on the face of this Bond. Such notices may be sent by personal delivery, commercial courier, or by United States Registered or Certified Mail, return receipt requested, postage pre-paid, and shall be deemed to be effective upon receipt by the party concerned.
9. Surety shall cause to be attached to this Bond a current and effective Power of Attorney evidencing the authority of the officer, agent, or representative who executed this Bond on behalf of Surety to execute, seal, and deliver such Bond and bind the Surety thereby.
10. This Bond is intended to conform to all applicable statutory requirements. Any applicable requirement of any applicable statute that has been omitted from this Bond shall be deemed to be included herein as if set forth at length. If any provision of this Bond conflicts with any applicable statute, then the provision of said statute shall govern and the remainder of this Bond that is not in conflict therewith shall continue in full force and effect.
11. The term "Bid" as used herein includes a Bid, offer, or proposal as applicable.

**BID FORM**

Project Identification: City of Pembroke, Kentucky  
Westbrooke Circle Drainage Repair Project

Contract Identification: Contract No. 1 – Drainage Repair Project

**ARTICLE 1 – BID RECIPIENT**

1.01 This Bid is Submitted to: City of Pembroke  
P.O. Box 162  
Pembroke, Kentucky 42266

1.02 The undersigned Bidder proposes and agrees, if this Bid is accepted, to enter into an Agreement with Owner to perform all Work as specified or indicated in the Bidding Documents for the prices and within the times indicated in the Bid and in accordance with the other terms and conditions of the Bidding Documents.

**ARTICLE 2 – BIDDER’S ACKNOWLEDGMENTS**

2.01 Bidder accepts all of the terms and conditions of the Advertisement and Instructions to Bidders, including without limitations those dealing with the dispositions of Bid security. The Bid will remain subject to acceptance for 90 days after the Bid opening, or for such longer period of time that Bidder may agree to in writing upon request of Owner.

**ARTICLE 3 – BIDDER’S REPRESENTATIONS**

3.01 In submitting this Bid, Bidder represents that:

A. Bidder has examined and carefully studied the Bidding Documents, the other related data identified in the Bidding Documents, and the following Addenda, receipt of which is hereby acknowledged.

Addendum No. \_\_\_\_\_ Dated \_\_\_\_\_  
Addendum No. \_\_\_\_\_ Dated \_\_\_\_\_  
Addendum No. \_\_\_\_\_ Dated \_\_\_\_\_  
Addendum No. \_\_\_\_\_ Dated \_\_\_\_\_

B. Bidder has visited the Site and become familiar with and is satisfied as to the general, local, and Site conditions that may affect cost, progress, and performance of the Work.

C. Bidder is familiar with and is satisfied as to all Federal, State, and local Laws and Regulations that may affect cost, progress, and performance of the Work.

D. Bidder has carefully studied all: (1) reports, if any, of explorations and tests of subsurface conditions at or contiguous to the Site and all drawings of physical conditions in or relating to existing surface or subsurface structures at or contiguous to the Site (except Underground Facilities).

E. Bidder has obtained and carefully studied (or accepts the consequences for not doing so) all additional or supplementary examinations, investigations, explorations, tests, studies, and data concerning conditions (surface, subsurface and Underground Facilities) at or contiguous to the Site which may affect cost, progress, or performance of the Work or which relate to any aspect of the means, methods, techniques, sequences, and procedures of construction to be employed by the Bidder, including applying the specific means, methods, techniques, sequences, and procedures of construction expressly required by the Bidding Documents to be employed by Bidder, and safety precautions and programs incident thereto.

F. Bidder does not consider that any further examinations, investigations, explorations, tests, studies, or data are necessary for the determination of this Bid for performance of the Work at the price(s) bid and within the times and in accordance with the other terms and conditions of the Bidding Documents.

- G. Bidder is aware of the general nature of the Work to be performed by Owner and others at the Site that relates to the Work as indicated in the Bidding Documents.
- H. Bidder has correlated the information known to Bidder, information and observations obtained from visits to the Site, reports and drawings identified in the Bidding Documents, and all additional examinations, investigations, explorations, tests, studies, and data with the Bidding Documents.
- I. Bidder has given Engineer written notice of all conflicts, errors, ambiguities, or discrepancies that Bidder has discovered in the Bidding Documents, and the written resolution thereof by Engineer is acceptable to Bidder.
- J. The Bidding Documents are generally sufficient to indicate and convey understanding of all terms and conditions for the performance of the Work for which this Bid is submitted.
- K. Bidder will submit written evidence of its authority to do business in the State where the Project is located not later than the date of its execution of the Agreement.

#### **ARTICLE 4 – FURTHER REPRESENTATIONS**

4.01 Bidder further represents that:

- A. This Bid is genuine and not made in the interest of or on the behalf of any undisclosed individual or entity and is not submitted in conformity with any agreement or rules of any group, association, organization, or corporation;
- B. Bidder has not directly or indirectly induced or solicited any other Bidder to submit a false or sham Bid;
- C. Bidder has not solicited or induced any individual or entity to refrain from bidding; and
- D. Bidder has not sought by collusion to obtain for itself any advantage over any other Bidder or over Owner.

**ARTICLE 5 – BASIS OF BID**

5.01 In compliance with the Advertisement for Bids, BIDDER hereby proposes to furnish all materials and labor for the work required for full and final completion of the “**Westbrooke Circle Drainage Repair Project**”, in strict accordance with the CONTRACT DOCUMENTS, within the time set forth herein for the Lump Sum Base Bid amount of:

<b>Total Lump Sum Bid Price for Base Bid Work</b>	\$
---	----

---

Dollars (\$) )

---

*Amount shall be shown in both words and figures. In case of discrepancy, the amount shown in words shall govern.*

**ARTICLE 6 – TIME OF COMPLETION**

- 6.01 Bidder agrees that the Work will be substantially complete within the number of calendar days, indicated in the Agreement.
- 6.02 Bidder accepts the provisions of the Agreement as to liquidated damages in the event of failure to complete the work within the Contract Time.

**ARTICLE 7 – ATTACHMENTS TO THIS BID**

- 7.01 The following documents are attached to and made a condition of the Bid:
  - A. Required Bid security in the form of a Bid Bond or Certified Check (circle type of security provided);
  - B. List of Subcontractors.
  - C. Statement of Experience

**ARTICLE 8 – DEFINED TERMS**

8.01 The terms used in this Bid with the initial capital letters have the meanings indicated in the Instructions to Bidders, the General Conditions, and the Special Conditions.

**ARTICLE 9 – BID SUBMITTAL**

9.01 This Bid submitted by:

Submitted by:

_____	_____
Signature	Business
_____	_____
Printed or Typed Name	Bidder's Business Address
_____	_____
Title	City, State, Zip Code
_____	_____
Employer's Tax ID No.	Business Phone No.      Business Fax No.
_____	_____
Business Email Address	Cell Phone No.      Other Contact No.

9.02 Bid submitted on \_\_\_\_\_, 2019.

Seal at right (if required)

## LIST OF SUBCONTRACTORS

The following SUBCONTRACTORS are proposed for work on the PROJECT.

No.	Subcontractor Name, Address & Phone No.	Work Item(s)
1.	<hr/> <hr/> <hr/>	<hr/> <hr/> <hr/>
2.	<hr/> <hr/> <hr/>	<hr/> <hr/> <hr/>
3.	<hr/> <hr/> <hr/>	<hr/> <hr/> <hr/>
4.	<hr/> <hr/> <hr/>	<hr/> <hr/> <hr/>
5.	<hr/> <hr/> <hr/>	<hr/> <hr/> <hr/>
6.	<hr/> <hr/> <hr/>	<hr/> <hr/> <hr/>
7.	<hr/> <hr/> <hr/>	<hr/> <hr/> <hr/>

Bidder

## STATEMENT OF EXPERIENCE

The following list represents the most recent clients for whom similar work was performed by the BIDDER. The persons listed may be contacted as references. Provide at least four unique and non-Owner related project references.

<b>No.</b>	<b>Contact Person, Company &amp; Phone No.</b>	<b>Project Description, Date &amp; Approximate Value of Work</b>
1.	_____ _____ _____	_____ _____ _____
2.	_____ _____ _____	_____ _____ _____
3.	_____ _____ _____	_____ _____ _____
4.	_____ _____ _____	_____ _____ _____
5.	_____ _____ _____	_____ _____ _____
6.	_____ _____ _____	_____ _____ _____

\_\_\_\_\_  
Bidder

## NOTICE OF AWARD

TO: Attention:Contractor  
Name of Company  
Address  
City, State, Zip

PROJECT Description: **City of Pembroke**  
**Westbrooke Circle Drainage Repair Project**

The OWNER has considered the BID submitted by you for the above-described WORK in response to its Advertisement for Bids dated November 5, 2019 and Instructions to Bidders.

You are hereby notified that your BID has been accepted for items in the amount of \_\_\_\_\_.

You are required by the Instructions to Bidders to execute the Agreement and furnish the required CONTRACTOR'S Performance BOND, Payment BOND and certificates of insurance within fifteen (15) calendar days from the date of a tentative award to you.

If you fail to execute said Agreement and to furnish said BONDS within fifteen (15) days from the date of this Notice, said OWNER will be entitled to consider all your rights arising out of the OWNER's acceptance of your BID as abandoned and as a forfeiture of your BID BOND. The OWNER will be entitled to such other rights as may be granted by law.

You are required to return an acknowledged copy of this NOTICE OF AWARD to the OWNER.

Dated this \_\_\_\_ day of \_\_\_\_\_ 2019.

**CITY OF PEMBROKE**

\_\_\_\_\_  
Judy Peterson, Mayor

## ACCEPTANCE OF NOTICE

Receipt of the above NOTICE OF AWARD is hereby acknowledged.

**CONTRACTOR**

\_\_\_\_\_  
Owner

\_\_\_\_\_  
Date Signed



## AGREEMENT

THIS AGREEMENT, made this \_\_\_\_\_ day of \_\_\_\_\_, 2019 by and between the **City of Pembroke** hereinafter called "OWNER" and \_\_\_\_\_ doing business as:

a corporation  a partnership  an individual (check one) hereinafter called "CONTRACTOR".

WITNESSETH: That for and in consideration of the payments and agreements herein after mentioned:

1. The CONTRACTOR will commence and complete the construction of the **City of Pembroke's Westbrooke Circle Drainage Rehab Project**.
2. The CONTRACTOR will furnish all of the materials, supplies, tools, equipment, labor, and other services necessary for the construction and completion of the PROJECT described herein.
3. The CONTRACTOR will commence the work required by the CONTRACT DOCUMENTS within 10 calendar days after the date of the NOTICE TO PROCEED and will complete the same within **30 calendar days** unless the period for completion is extended otherwise by the CONTRACT DOCUMENTS.
4. The CONTRACTOR agrees to perform all of the WORK described in the CONTRACT DOCUMENTS and comply with the terms therein for the price(s) shown in the BID schedule.
5. The term "CONTRACT DOCUMENTS" means and includes the following:

(A) Advertisement For BIDS	(B) Information For BIDDERS
(C) BID	(D) (not used)
(E) Agreement	(F) General Conditions
(G) SUPPLEMENTAL GENERAL CONDITIONS	(H) Payment BOND
(I) Performance BOND	(J) NOTICE OF AWARD
(K) NOTICE TO PROCEED	(L) CHANGE ORDER(S)
(M) DRAWINGS prepared by <b>McGhee Engineering, Inc.</b>	
(N) SPECIFICATIONS prepared or issued by <b>McGhee Engineering, Inc.</b>	
(O) ADDENDA.	
6. The OWNER will pay to the CONTRACTOR in the manner and at such times as set forth in the General Conditions such amounts as required by the CONTRACT DOCUMENTS.
7. This Agreement shall be binding upon all parties hereto and their respective heirs, executors, administrators, successors, and assigns.

IN WITNESS WHEREOF, the parties hereto have executed or caused to be executed by their duly authorized official, this Agreement in four copies each of which shall be deemed an original on the date first above written.

**City of Pembroke**  
222 S Main St  
Pembroke, Kentucky 42266

**(Contractor)**  
Address  
City

By: \_\_\_\_\_  
Judy Peterson, Mayor

By: \_\_\_\_\_  
Name, Title

Attest: \_\_\_\_\_

Attest: \_\_\_\_\_

# PERFORMANCE BOND

Any singular reference to Contractor, Surety, Owner, or other party shall be considered plural where applicable.

---

CONTRACTOR (*Name and Address*):                      SURETY (*Name, and Address of Principal Place of Business*):

OWNER (*Name and Address*):

**City of Pembroke**  
**222 S Main St**  
**Pembroke, KY 42266**

CONTRACT

Effective Date of Agreement:  
Amount:  
Description (*Name and Location*):

BOND

Bond Number:  
Date (*Not earlier than Effective Date of Agreement*):  
Amount:  
Modifications to this Bond Form:

Surety and Contractor, intending to be legally bound hereby, subject to the terms set forth below, do each cause this Performance Bond to be duly executed by an authorized officer, agent, or representative.

**CONTRACTOR AS PRINCIPAL**

**SURETY**

\_\_\_\_\_  
Contractor's Name and Corporate Seal (Seal)

\_\_\_\_\_  
Surety's Name and Corporate Seal (Seal)

By: \_\_\_\_\_  
Signature

By: \_\_\_\_\_  
Signature (Attach Power of Attorney)

\_\_\_\_\_  
Print Name

\_\_\_\_\_  
Print Name

\_\_\_\_\_  
Title

\_\_\_\_\_  
Title

Attest: \_\_\_\_\_  
Signature

Attest: \_\_\_\_\_  
Signature

\_\_\_\_\_  
Title

\_\_\_\_\_  
Title

*Note: Provide execution by additional parties, such as joint venturers, if necessary.*

Contractor and Surety, jointly and severally, bind themselves, their heirs, executors, administrators, successors, and assigns to Owner for the performance of the Contract, which is incorporated herein by reference.

1. If Contractor performs the Contract, Surety and Contractor have no obligation under this Bond, except to participate in conferences as provided in Paragraph 2.1.
2. If there is no Owner Default, Surety's obligation under this Bond shall arise after:
  - 2.1 Owner has notified Contractor and Surety, at the addresses described in Paragraph 9 below, that Owner is considering declaring a Contractor Default and has requested and attempted to arrange a conference with Contractor and Surety to be held not later than 15 days after receipt of such notice to discuss methods of performing the Contract. If Owner, Contractor, and Surety agree, Contractor shall be allowed a reasonable time to perform the Contract, but such an agreement shall not waive Owner's right, if any, subsequently to declare a Contractor Default; and
  - 2.2 Owner has declared a Contractor Default and formally terminated Contractor's right to complete the Contract. Such Contractor Default shall not be declared earlier than 20 days after Contractor and Surety have received notice as provided in Paragraph 2.1; and
  - 2.3 Owner has agreed to pay the Balance of the Contract Price to:
    1. Surety in accordance with the terms of the Contract; or
    2. Another contractor selected pursuant to Paragraph 3.3 to perform the Contract.
3. When Owner has satisfied the conditions of Paragraph 2, Surety shall promptly, and at Surety's expense, take one of the following actions:
  - 3.1 Arrange for Contractor, with consent of Owner, to perform and complete the Contract; or
  - 3.2 Undertake to perform and complete the Contract itself, through its agents or through independent contractors; or
  - 3.3 Obtain bids or negotiated proposals from qualified contractors acceptable to Owner for a contract for performance and completion of the Contract, arrange for a contract to be prepared for execution by Owner and contractor selected with Owner's concurrence, to be secured with performance and payment bonds executed by a qualified surety equivalent to the bonds issued on the Contract, and pay to Owner the amount of damages as described in Paragraph 5 in excess of the Balance of the Contract Price incurred by Owner resulting from Contractor Default; or
  - 3.4 Waive its right to perform and complete, arrange for completion, or obtain a new contractor, and with reasonable promptness under the circumstances:
    1. After investigation, determine the amount for which it may be liable to Owner and, as soon as practicable after the amount is determined, tender payment therefor to Owner; or
    2. Deny liability in whole or in part and notify Owner citing reasons therefore.
4. If Surety does not proceed as provided in Paragraph 3 with reasonable promptness, Surety shall be deemed to be in default on this Bond 15 days after receipt of an additional written notice from Owner to Surety demanding that Surety perform its obligations under this Bond, and Owner shall be entitled to enforce any remedy available to Owner. If Surety proceeds as provided in Paragraph 3.4, and Owner refuses the payment tendered or Surety has denied liability, in whole or in part, without further notice Owner shall be entitled to enforce any remedy available to Owner.
5. After Owner has terminated Contractor's right to complete the Contract, and if Surety elects to act under Paragraph 3.1, 3.2, or 3.3 above, then the responsibilities of Surety to Owner shall not be greater than those of Contractor under the Contract, and the responsibilities of Owner to Surety shall not be greater than those of Owner under the Contract. To the limit of the amount of this Bond, but subject to commitment by Owner of the Balance of the Contract Price to mitigation of costs and damages on the Contract, Surety is obligated without duplication for:

- 5.1 The responsibilities of Contractor for correction of defective Work and completion of the Contract;
- 5.2 Additional legal, design professional, and delay costs resulting from Contractor's Default, and resulting from the actions of or failure to act of Surety under Paragraph 3; and
- 5.3 Liquidated damages, or if no liquidated damages are specified in the Contract, actual damages caused by delayed performance or non-performance of Contractor.

6. Surety shall not be liable to Owner or others for obligations of Contractor that are unrelated to the Contract, and the Balance of the Contract Price shall not be reduced or set off on account of any such unrelated obligations. No right of action shall accrue on this Bond to any person or entity other than Owner or its heirs, executors, administrators, or successors.

7. Surety hereby waives notice of any change, including changes of time, to Contract or to related subcontracts, purchase orders, and other obligations.

8. Any proceeding, legal or equitable, under this Bond may be instituted in any court of competent jurisdiction in the location in which the Work or part of the Work is located, and shall be instituted within two years after Contractor Default or within two years after Contractor ceased working or within two years after Surety refuses or fails to perform its obligations under this Bond, whichever occurs first. If the provisions of this paragraph are void or prohibited by law, the minimum period of limitation available to sureties as a defense in the jurisdiction of the suit shall be applicable.

9. Notice to Surety, Owner, or Contractor shall be mailed or delivered to the address shown on the signature page.

10. When this Bond has been furnished to comply with a statutory requirement in the location where the Contract was to be performed, any provision in this Bond conflicting with said statutory requirement shall be deemed deleted herefrom and provisions conforming to such statutory requirement shall be deemed incorporated herein. The intent is that this Bond shall be construed as a statutory bond and not as a common law bond.

11. Definitions.

- 11.1 Balance of the Contract Price: The total amount payable by Owner to Contractor under the Contract after all proper adjustments have been made, including allowance to Contractor of any amounts received or to be received by Owner in settlement of insurance or other Claims for damages to which Contractor is entitled, reduced by all valid and proper payments made to or on behalf of Contractor under the Contract.
- 11.2 Contract: The agreement between Owner and Contractor identified on the signature page, including all Contract Documents and changes thereto.
- 11.3 Contractor Default: Failure of Contractor, which has neither been remedied nor waived, to perform or otherwise to comply with the terms of the Contract.
- 11.4 Owner Default: Failure of Owner, which has neither been remedied nor waived, to pay Contractor as required by the Contract or to perform and complete or otherwise comply with the other terms thereof.

FOR INFORMATION ONLY – <i>(Name, Address and Telephone)</i> Surety Agency or Broker: Owner's Representative <i>(Engineer or other party)</i> :
--

# PAYMENT BOND

Any singular reference to Contractor, Surety, Owner, or other party shall be considered plural where applicable.

---

CONTRACTOR (*Name and Address*):

SURETY (*Name, and Address of Principal Place of Business*):

OWNER (*Name and Address*):

**City of Pembroke**  
**222 S Main St**  
**Pembroke, KY 42266**

CONTRACT

Effective Date of Agreement:

Amount:

Description (*Name and Location*):

BOND

Bond Number:

Date (*Not earlier than Effective Date of Agreement*):

Amount:

Modifications to this Bond Form:

Surety and Contractor, intending to be legally bound hereby, subject to the terms set forth below, do each cause this Payment Bond to be duly executed by an authorized officer, agent, or representative.

**CONTRACTOR AS PRINCIPAL**

**SURETY**

\_\_\_\_\_  
Contractor's Name and Corporate Seal (Seal)

\_\_\_\_\_  
Surety's Name and Corporate Seal (Seal)

By: \_\_\_\_\_  
Signature

By: \_\_\_\_\_  
Signature (Attach Power of Attorney)

\_\_\_\_\_  
Print Name

\_\_\_\_\_  
Print Name

\_\_\_\_\_  
Title

\_\_\_\_\_  
Title

Attest: \_\_\_\_\_  
Signature

Attest: \_\_\_\_\_  
Signature

\_\_\_\_\_  
Title

\_\_\_\_\_  
Title

*Note: Provide execution by additional parties, such as joint venturers, if necessary.*

1. Contractor and Surety, jointly and severally, bind themselves, their heirs, executors, administrators, successors, and assigns to Owner to pay for labor, materials, and equipment furnished by Claimants for use in the performance of the Contract, which is incorporated herein by reference.
2. With respect to Owner, this obligation shall be null and void if Contractor:
  - 2.1 Promptly makes payment, directly or indirectly, for all sums due Claimants, and
  - 2.2 Defends, indemnifies, and holds harmless Owner from all claims, demands, liens, or suits alleging non-payment by Contractor by any person or entity who furnished labor, materials, or equipment for use in the performance of the Contract, provided Owner has promptly notified Contractor and Surety (at the addresses described in Paragraph 12) of any claims, demands, liens, or suits and tendered defense of such claims, demands, liens, or suits to Contractor and Surety, and provided there is no Owner Default.
3. With respect to Claimants, this obligation shall be null and void if Contractor promptly makes payment, directly or indirectly, for all sums due.
4. Surety shall have no obligation to Claimants under this Bond until:
  - 4.1 Claimants who are employed by or have a direct contract with Contractor have given notice to Surety (at the address described in Paragraph 12) and sent a copy, or notice thereof, to Owner, stating that a claim is being made under this Bond and, with substantial accuracy, the amount of the claim.
  - 4.2 Claimants who do not have a direct contract with Contractor:
    1. Have furnished written notice to Contractor and sent a copy, or notice thereof, to Owner, within 90 days after having last performed labor or last furnished materials or equipment included in the claim stating, with substantial accuracy, the amount of the claim and the name of the party to whom the materials or equipment were furnished or supplied, or for whom the labor was done or performed; and
    2. Have either received a rejection in whole or in part from Contractor, or not received within 30 days of furnishing the above notice any communication from Contractor by which Contractor had indicated the claim will be paid directly or indirectly; and
    3. Not having been paid within the above 30 days, have sent a written notice to Surety (at the address described in Paragraph 12) and sent a copy, or notice thereof, to Owner, stating that a claim is being made under this Bond and enclosing a copy of the previous written notice furnished to Contractor.
5. If a notice by a Claimant required by Paragraph 4 is provided by Owner to Contractor or to Surety, that is sufficient compliance.
6. Reserved.
7. Surety's total obligation shall not exceed the amount of this Bond, and the amount of this Bond shall be credited for any payments made in good faith by Surety.
8. Amounts owed by Owner to Contractor under the Contract shall be used for the performance of the Contract and to satisfy claims, if any, under any performance bond. By Contractor furnishing and Owner accepting this Bond, they agree that all funds earned by Contractor in the performance of the Contract are dedicated to satisfy obligations of Contractor and Surety under this Bond, subject to Owner's priority to use the funds for the completion of the Work.
9. Surety shall not be liable to Owner, Claimants, or others for obligations of Contractor that are unrelated to the Contract. Owner shall not be liable for payment of any costs or expenses of any Claimant under this Bond, and shall have under this Bond no obligations to make payments to, give notices on behalf of, or otherwise have obligations to Claimants under this Bond.

10. Surety hereby waives notice of any change, including changes of time, to the Contract or to related subcontracts, purchase orders, and other obligations.

11. No suit or action shall be commenced by a Claimant under this Bond other than in a court of competent jurisdiction in the location in which the Work or part of the Work is located or after the expiration of one year from the date (1) on which the Claimant gave the notice required by Paragraph 4.1 or Paragraph 4.2.3, or (2) on which the last labor or service was performed by anyone or the last materials or equipment were furnished by anyone under the Contract, whichever of (1) or (2) first occurs. If the provisions of this paragraph are void or prohibited by law, the minimum period of limitation available to sureties as a defense in the jurisdiction of the suit shall be applicable.

12. Notice to Surety, Owner, or Contractor shall be mailed or delivered to the addresses shown on the signature page. Actual receipt of notice by Surety, Owner, or Contractor, however accomplished, shall be sufficient compliance as of the date received at the address shown on the signature page.

13. When this Bond has been furnished to comply with a statutory requirement in the location where the Contract was to be performed, any provision in this Bond conflicting with said statutory requirement shall be deemed deleted herefrom and provisions conforming to such statutory requirement shall be deemed incorporated herein. The intent is that this Bond shall be construed as a statutory Bond and not as a common law bond.

14. Upon request of any person or entity appearing to be a potential beneficiary of this Bond, Contractor shall promptly furnish a copy of this Bond or shall permit a copy to be made.

15. Definitions

15.1 Claimant: An individual or entity having a direct contract with Contractor, or with a first-tier subcontractor of Contractor, to furnish labor, materials, or equipment for use in the performance of the Contract. The intent of this Bond shall be to include without limitation in the terms “labor, materials or equipment” that part of water, gas, power, light, heat, oil, gasoline, telephone service, or rental equipment used in the Contract, architectural and engineering services required for performance of the Work of Contractor and Contractor’s subcontractors, and all other items for which a mechanic’s lien may be asserted in the jurisdiction where the labor, materials, or equipment were furnished.

15.2 Contract: The agreement between Owner and Contractor identified on the signature page, including all Contract Documents and changes thereto.

15.3 Owner Default: Failure of Owner, which has neither been remedied nor waived, to pay Contractor as required by the Contract, or to perform and complete or otherwise comply with the other terms thereof.

FOR INFORMATION ONLY – *(Name, Address, and Telephone)*

Surety Agency or Broker:

Owner’s Representative *(Engineer or other)*:

**NOTICE TO PROCEED**

TO: \_\_\_\_\_  
\_\_\_\_\_  
\_\_\_\_\_

DATE: \_\_\_\_\_

PROJECT: **City of Pembroke**  
**Westbrooke Circle Drainage Repair Project**

You are hereby notified to commence WORK in accordance with the Agreement dated \_\_\_\_\_, 2019 on or before \_\_\_\_\_, **2019**, and you are to complete the WORK within **30** consecutive calendar days thereafter. The date of completion of all WORK is therefore \_\_\_\_\_, **2019**.

**CITY OF PEMBROKE**

\_\_\_\_\_  
Judy Peterson, Mayor

**ACCEPTANCE OF NOTICE**

Receipt of the above NOTICE TO PROCEED is hereby acknowledged and dated this \_\_\_\_ day of \_\_\_\_\_ 2019.

**(Contractor)**

\_\_\_\_\_  
Name, Title

\_\_\_\_\_  
Employer Identification Number



**TABLE OF CONTENTS**  
**for**  
**GENERAL CONDITIONS OF AGREEMENT**

		<u>Page</u>
	1. Definition of Terms	
1.01	Owner, Contractor and Engineer	3
1.02	Contract Documents	3
1.03	Sub-Contractor	3
1.04	Written Notice	3
1.05	Work	3
1.06	Extra Work	3
1.07	Working Day	3
1.08	Calendar Day	3
1.09	Substantially Completed	3
	2. Responsibilities of the Engineer and Contractor	
2.01	Owner-Engineer Relationship	4
2.02	Professional Inspection by Engineer	4
2.03	Payments for Work	4
2.04	Initial Determinations	4
2.05	Objections	4
2.06	Lines and Grades	4
2.07	Contractor's Duty and Superintendence	4
2.08	Contractor's Understanding	5
2.09	Character of Workmen	5
2.10	Contractor's Buildings	5
2.11	Sanitation	6
2.12	Shop Drawings	6
2.13	Preliminary Approval	6
2.14	Defects and Their Remedies	6
2.15	Changes and Alterations	6
	3. General Obligations and Responsibilities	
3.01	Keeping of Plans and Specifications Accessible	7
3.02	Ownership of Drawings	7
3.03	Adequacy of Design	7
3.04	Right of Entry	7
3.05	Collateral Contracts	7
3.06	Discrepancies and Omissions	7
3.07	Equipment, Materials and Construction Plant	7
3.08	Damages	8
3.09	Protection Against Accident to Employees and the Public	8
3.10	Performance, Payment and Maintenance Bonds	8
3.11	Losses from Natural Causes	8
3.12	Protection of Adjoining Property	8
3.13	Protection Against Claims of Subcontractors, Etc.	8
3.14	Protection Against Royalties or Patented Invention	9
3.15	Laws and Ordinances	9
3.16	Assignment and Subletting	9
3.17	Indemnification	9
3.18	Insurance	10
3.19	Certificate of Insurance	10

	4. Prosecution and Progress	
4.01	Time and Order of Completion	10
4.02	Extension of Time	10
4.03	Hindrances and Delays	11
	5. Measurement and Payment	
5.01	Quantities and Measurements	11
5.02	Estimated Quantities	11
5.03	Price of Work	11
5.04	Partial Payment	11
5.05	Use of Completed Portions	12
5.06	Final Completion and Acceptance	12
5.07	Final Payment	12
5.08	Payments Withheld	12
5.09	Delayed Payments	13
	6. Extra Work and Claims	
6.01	Change Orders	13
6.02	Minor Changes	13
6.03	Extra Work	13
6.04	Time of Filing Claims	14
6.05	Arbitration	14
	7. Abandonment of Contract	
7.01	Abandonment by Contractor	15
7.02	Abandonment by Owner	16

## GENERAL CONDITIONS OF AGREEMENT

### 1. DEFINITION OF TERMS

- 1.01 **OWNER, CONTRACTOR AND ENGINEER.** The OWNER, the CONTRACTOR, and the ENGINEER are those persons or organizations identified as such in the Agreement and are referred to throughout the Contract Documents as if singular in number and masculine in gender. The term ENGINEER means the ENGINEER or his duly authorized representative. The ENGINEER shall be understood to be the ENGINEER of the OWNER, and nothing contained in the Contract Documents shall create any contractual or agency relationship between the ENGINEER and the CONTRACTOR.
- 1.02 **CONTRACT DOCUMENTS.** The Contract Documents shall consist of the Notice to Contractors (Advertisement), Special Conditions, Instructions to Bidders, Proposal, signed Agreement, Performance and Payment Bonds (when required), Special Bonds (when required), General Conditions of the Agreement, Technical Specifications, Plans, and all modifications thereof incorporated in any of the documents before the execution of the agreement.
- The Contract Documents are complementary, and what is called for by any one shall be as binding as if called for by all. In case of conflict between any of the Contract Documents priority of interpretation shall be in the following order: Signed Agreement, Performance and Payment Bonds, Special Bonds (if any), Proposal, Special Conditions of Agreement, Notice to Contractors, Technical Specifications, Plans, and General Conditions of Agreement.
- 1.03 **SUB-CONTRACTOR.** The term Sub-Contractor, as employed herein, includes only those having a direct contract with the CONTRACTOR and it includes one who furnishes material worked to a special design according to the plans or specifications of this work, but does not include one who merely furnishes material not so worked.
- 1.04 **WRITTEN NOTICE.** Written notice shall be deemed to have been duly served if delivered in person to the individual or to a member of the firm or to an officer of the corporation for whom it is intended, or if delivered at or sent by registered mail to the last business address known to him who gives the notice.
- 1.05 **WORK.** The CONTRACTOR shall provide and pay for all materials, supplies, machinery, equipment, tools, superintendence, labor, services, insurance, and all water, light, power, fuel, transportation and other facilities necessary for the execution and completion of the work covered by the contract documents. Unless otherwise specified, all materials shall be new and both workmanship and materials shall be of a good quality. The CONTRACTOR shall if required, furnish satisfactory evidence as to the kind and quality of materials. Materials or work described in words which so applied have a well known technical or trade meaning shall be held to refer to such recognized standards.
- 1.06 **EXTRA WORK.** The term "Extra Work" as used in this contract shall be understood to mean and include all work that may be required by the ENGINEER or OWNER to be done by the CONTRACTOR to accomplish any change, alteration or addition to the work shown upon the plans, or reasonably implied by the specifications, and not covered by the CONTRACTOR'S Proposal, except as provided under "Changes and Alterations", herein.
- 1.07 **WORKING DAY.** A "Working Day" is defined as any day not including Saturdays, Sundays or any legal holidays, in which weather or other conditions, not under the control of the CONTRACTOR, will permit construction of the principal units of the work for a period of not less than seven (7) hours between 7:00 a.m. and 6:00 p.m.
- 1.08 **CALENDAR DAY.** "Calendar Day" is any day of the week or month, no days being excepted.
- 1.09 **SUBSTANTIALLY COMPLETED.** By the term "substantially completed" is meant that the structure has been made suitable for use or occupancy or the facility is in condition to serve its intended purpose, but still may require minor miscellaneous work and adjustment.

## 2. RESPONSIBILITIES OF THE ENGINEER AND THE CONTRACTOR

- 2.01 OWNER-ENGINEER RELATIONSHIP. The ENGINEER will be the OWNER'S representative during construction. The duties, responsibilities and limitations of authority of the ENGINEER as the OWNER'S representative during construction are as set forth in the Contract Documents and shall not be extended or limited without written consent of the OWNER, and ENGINEER. The ENGINEER will advise and consult with the OWNER, and all of the OWNER'S instructions to the CONTRACTOR shall be issued through the ENGINEER.
- 2.02 CONSTRUCTION OBSERVATION BY ENGINEER. The ENGINEER shall make periodic visits to the site to familiarize himself generally with the progress of the executed work and to determine if such work generally meets the essential performance and design features and the technical and functional engineering requirements of the Contract Documents; provided and except, however, that the ENGINEER shall not be responsible for making any detailed, exhaustive, comprehensive or continuous on-site inspection of the quality or quantity of the work or be in any way responsible, directly or indirectly, for the construction means, methods, techniques, sequences, quality, procedures, programs, safety precautions or lack of same incident thereto or in connection therewith. Notwithstanding any other provision of this agreement or any other Contract Document, The ENGINEER shall not be in any way responsible or liable for any acts, errors, omissions or negligence of the CONTRACTOR, any subcontractor or any of the CONTRACTOR'S or subcontractor's agents, servants or employees or any other person, firm or corporation performing or attempting to perform any of the work.
- 2.03 PAYMENTS FOR WORK. The ENGINEER shall review CONTRACTOR'S applications for payment and supporting data, determine the amount owed to the CONTRACTOR and approve, in writing payment to CONTRACTOR in such amounts; such approval of payment to CONTRACTOR constitutes a representation to the OWNER of ENGINEER'S professional judgment that the work has progressed to the point indicated to the best of his knowledge, information and belief, but such approval of an application for payment to CONTRACTOR shall not be deemed as a representation by the ENGINEER that the ENGINEER has made any examination to determine how or for what purpose the CONTRACTOR has used the moneys paid on account of the Contract price.
- 2.04 DETERMINATIONS. The ENGINEER initially shall determine all claims, disputes and other matters in question between the CONTRACTOR and the OWNER relating to the execution or progress of the work or the interpretation of the Contract Documents and the ENGINEER'S decision shall be rendered in writing within a reasonable time. Should the ENGINEER fail to make such decision within a reasonable time, appeal to arbitration may be taken as if his decision had been rendered against the party appearing.
- 2.05 OBJECTIONS. In the event the ENGINEER renders any decision which, in the opinion of either party hereto, is not in accordance with the meaning and intent of this contract, either party may file with the ENGINEER within thirty days his written objection to the decision, and by such action may reserve the right to submit the question so raised to arbitration as hereinafter provided.
- 2.06 LINES AND GRADES. Unless otherwise specified, all lines and grades shall be furnished by the ENGINEER or his representative. Whenever necessary, construction work shall be suspended to permit performance of this work, but such suspension will be as brief as practicable and the CONTRACTOR shall be allowed no extra compensation therefor. The CONTRACTOR shall give the ENGINEER ample notice of the time and place where lines and grades will be needed. All stakes, marks, etc., shall be carefully preserved by the CONTRACTOR, and in case of careless destruction or removal by him or his employees, such stakes, marks, etc., shall be replaced at the CONTRACTOR'S expense.
- 2.07 CONTRACTOR'S DUTY AND SUPERINTENDENCE. The CONTRACTOR shall give adequate attention to the faithful prosecution and completion of this contract and shall keep on the work, during its progress, a competent superintendent and any necessary assistants. The superintendent shall represent the CONTRACTOR in his absence and all directions given to him shall be as binding as if given to the CONTRACTOR. The CONTRACTOR is and at all times shall remain an independent contractor, solely responsible for the manner and method of completing his work under this contract, with full power and authority to select the means, method and manner of performing such work, so long as such methods do not adversely affect the completed improvements, the OWNER and ENGINEER being interested only in

the result obtained and conformity of such completed improvements to the plans, specifications and contract.

Likewise, the CONTRACTOR shall be solely responsible for the safety of himself, his employees and other persons, as well as for the protection of the safety of the improvements being erected and the property of himself or any other person, as a result of his operations hereunder. Engineering construction drawings and specifications as well as any additional information concerning the work to be performed passing from or through the ENGINEER shall not be interpreted as requiring or allowing CONTRACTOR to deviate from the plans and specifications, the intent of such drawings, specifications and any other such instructions being to define with particularity the agreement of the parties as to the work the CONTRACTOR is to perform. CONTRACTOR shall be fully and completely liable, at his own expense, for design, construction, installation and use, or non-use, of all items and methods incident to performance of the contract, and for all loss, damage or injury incident thereto, either to person or property, including, without limitation, the adequacy of all temporary supports, shoring, bracing, scaffolding, machinery or equipment, safety precautions or devices, and similar items or devices used by him during construction.

Any review of work in process, or any visit or observation during construction, or any clarification of plans and specifications, by the ENGINEER, or any agent, employee, or representative of either of them, whether through personal observation on the project site or by means of approval of shop drawings for temporary construction or construction processes, or by other means or method, is agreed by the CONTRACTOR to be for the purpose of observing the extent and nature of work completed or being performed, as measured against the drawings and specifications constituting the contract, or for the purpose of enabling CONTRACTOR to more fully understand the plans and specifications so that the completed construction work will conform thereto, and shall in no way relieve the CONTRACTOR from full and complete responsibility for the proper performance of his work on the project, including but without limitation the propriety of means and methods of the CONTRACTOR in performing said contract, and the adequacy of any designs, from plans and specifications that may have been in evidence during any such visitation or observation by the ENGINEER, or any of his representatives, whether called to the CONTRACTOR'S attention or not shall in no way relieve CONTRACTOR from his responsibility to complete all work in accordance with said plans and specifications.

- 2.08 CONTRACTOR'S UNDERSTANDING. It is understood and agreed that the CONTRACTOR has, by careful examination, satisfied himself as to the nature and location of the work, the conformation of the ground to that represented in the plans, the character, quantity and quality of the materials to be encountered, the availability of the necessary labor, materials and equipment required to perform the work, the character of equipment and facilities needed preliminary to and during the prosecution of the work, the general and local conditions, and all other matters which can in any way affect the work under this Contract. No verbal agreement or conversation with any officer, agent or employee of the OWNER or ENGINEER either before or after the execution of this contract, shall affect or modify any of the terms or obligations herein contained.
- 2.09 CHARACTER OF WORKMEN. The CONTRACTOR agrees to employ only orderly and competent workers, skillful in the performance of the type of work required under this contract, to do the work; and agrees that whenever the ENGINEER shall inform him in writing that any worker or workers on the work are, in his opinion, incompetent, unfaithful or disorderly, such worker or workers shall be discharged from the work and shall not again be employed on the work without the ENGINEER'S written consent.
- 2.10 CONTRACTOR'S BUILDINGS. The building of structures for housing workers, or the erection of enclosures or other forms of protection, will be permitted only at such places as the ENGINEER shall direct, and the sanitary conditions of the grounds in or about such structures shall at all times be maintained in a manner satisfactory to the ENGINEER.
- 2.11 SANITATION. Necessary sanitary conveniences for the use of laborers on the work, properly secluded from public observation, shall be constructed and maintained by the CONTRACTOR in such manner and at such points as shall be approved by the ENGINEER, and their use shall be strictly enforced.
- 2.12 SHOP DRAWINGS. The CONTRACTOR shall submit to the ENGINEER, with such promptness as to cause no delay in his own work or in that of any other Contractor six checked copies, unless otherwise specified, of all shop and/or setting drawings and schedules required for the work of the various trades,

and the ENGINEER shall pass upon them with reasonable promptness, making desired corrections, The CONTRACTOR shall make any corrections required by the ENGINEER, file with him six corrected copies and furnish such other copies as may be needed. The ENGINEER'S approval of such drawings or schedules shall not relieve the CONTRACTOR from responsibility for deviations from drawings or specifications, unless he has in writing called the ENGINEER'S attention to such deviations at the time of submission, nor shall it relieve him from responsibility for errors of any sort in shop drawings or schedules. It shall be the CONTRACTOR'S responsibility to fully and completely review all shop drawings to ascertain their effect on his ability to perform the required contract work in accordance with the plans and specifications and within the contract time.

Such review by the ENGINEER shall be for the sole purpose of determining the sufficiency of said drawings or schedules to result in finished improvements in conformity with the plans and specifications, and shall not relieve the contractor of his duty as an independent contractor as previously set forth, it being expressly understood and agreed that the ENGINEER does not assume any duty to pass upon the propriety or adequacy of such drawings or schedules, or any means or methods reflected thereby, in relation to the safety of either person or property during CONTRACTOR'S performance hereunder.

- 2.13 PRELIMINARY APPROVAL. The ENGINEER shall not have the power to waive the obligations of this contract for the furnishing by the CONTRACTOR of good material, and of his performing good work as herein described, and in full accordance with the plans and specifications. No failure or omission of the ENGINEER to discover, object to or condemn any defective work or material shall release the contractor from the obligations to fully and properly perform the contract, including without limitations, the obligation to at once tear out, remove and properly replace the same at any time prior to final acceptance upon the discovery of said defective work or material; provided, however, that the ENGINEER shall, upon request of the CONTRACTOR, inspect and accept or reject any material furnished, and in event the material has been once accepted by the ENGINEER, such acceptance shall be binding on the OWNER, unless it can be clearly shown that such material furnished does not meet the specifications for this work.

Any questioned work may be ordered taken up or removed for re-examination, by the ENGINEER, prior to final acceptance, and if found not in accordance with the specifications for said work, all expense of removing, re-examination and replacement shall be borne by the CONTRACTOR, otherwise the expense thus incurred shall be allowed as Extra Work, and shall be paid for by the OWNER; provided that, where inspection or approval is specifically required by the specifications prior to performance of certain work, should the CONTRACTOR proceed with such work without requesting prior inspection or approval he shall bear all expense of taking up, removing, and replacing this work if so directed by the ENGINEER.

- 2.14 DEFECTS AND THEIR REMEDIES. It is further agreed that if the work or any part thereof or any material brought on the site of the work for use in the work or selected for the same shall be deemed by the ENGINEER as unsuitable or not in conformity with the Specifications, the CONTRACTOR shall, after receipt of written notice thereof from the ENGINEER forthwith remove such material and rebuild or otherwise remedy such work so that it shall be in full accordance with this contract.

- 2.15 CHANGES AND ALTERATIONS. The CONTRACTOR further agrees that the OWNER may make such changes and alterations as the OWNER may see fit, in the line, grade, form, dimensions, plans or materials for the work herein contemplated, or any part thereof, either before or after the beginning of construction, without affecting the validity of this contract and the accompanying Performance and Payment Bonds.

If such changes or alterations diminish the quantity of the work to be done, they shall not constitute the basis for a claim for damages, or anticipated profits on the work that may be dispensed with, except as provided for unit price items under Section 5 'Measurement and Payment.' If the amount of work is increased, and the work can be fairly classified under the specifications, such increase shall be paid for according to the quantity actually done, and at the unit price, if any, established for such work under this contract, except as provided for unit price items under Section 5 'Measurement and Payment;' otherwise such additional work shall be paid for as provided under Extra Work. In case the OWNER shall make such changes or alterations as shall make useless any work already done or material already furnished or used in said work, then the OWNER shall recompense the CONTRACTOR for any material or labor so used, for any actual loss occasioned by such change, due to actual expenses occurred in preparation for the work as originally planned.

### 3. GENERAL OBLIGATIONS AND RESPONSIBILITIES

- 3.01 **KEEPING OF PLANS AND SPECIFICATIONS ACCESSIBLE.** The ENGINEER shall furnish the CONTRACTOR with an adequate and reasonable number of copies of all plans and specifications without expense to him, and the CONTRACTOR shall keep one copy of the same constantly accessible on the work, with the latest revisions noted thereon.
- 3.02 **OWNERSHIP OF DRAWINGS.** All drawings, specifications and copies thereof furnished by the ENGINEER shall not be reused on other work, and with the exception of the signed contract sets, are to be returned to him on request, at the completion of the work. All models are the property of the OWNER.
- 3.03 **ADEQUACY OF DESIGN.** It is understood that the OWNER believes it has employed competent engineers and designers. It is, therefore, agreed that the OWNER shall be responsible for the adequacy of the design, sufficiency of the Contract Documents, the safety of the structure and the practicability of the operations of the completed project; provided the CONTRACTOR has complied with the requirements of the said Contract Documents, all approved modifications thereof, and additions and alterations thereto approved in writing by the OWNER. The burden of proof of such compliance shall be upon the CONTRACTOR to show that he has complied with the said requirements of the Contract Documents, approved modifications thereof and all approved additions and alterations thereto.
- 3.04 **RIGHT OF ENTRY.** The OWNER reserves the right to enter the property or location on which the works herein contracted for are to be constructed or installed, by such agent or agents as he may elect, for the purpose of inspecting the work, or for the purpose of constructing or installing such collateral work as said OWNER may desire.
- 3.05 **COLLATERAL CONTRACTS.** The OWNER agrees to provide by separate contract or otherwise, all labor and material essential to the completion of the work specifically excluded from this contract, in such manner as not to delay the progress of the work, or damage said CONTRACTOR, except where such delays are specifically mentioned elsewhere in the Contract Documents.
- 3.06 **DISCREPANCIES AND OMISSIONS.** It is further agreed that it is the intent of this contract that all work must be done and all material must be furnished in accordance with the general accepted practice, and in the event of any discrepancy between the separate contract documents, the priority of interpretation defined under 'Contract Documents' shall govern. In the event that there is still any doubt as to the meaning and intent of any portion of the contract, specifications or drawings, the ENGINEER shall define which is intended to apply to the work.
- 3.07 **EQUIPMENT, MATERIALS AND CONSTRUCTION PLANT.** The CONTRACTOR shall be responsible for the care, preservation, conservation, and protection of all materials, supplies, machinery, equipment, tools, apparatus, accessories, facilities, all means of construction, and any and all parts of the work, whether the CONTRACTOR has been paid, partially paid, or not paid for such work, until the entire work is completed and accepted.
- 3.08 **DAMAGES.** In the event the CONTRACTOR is damaged in the course of the completion of the work by the act, neglect, omission, mistake or default of the OWNER, or of the ENGINEER, or of any other CONTRACTOR, the OWNER agrees that he will reimburse the CONTRACTOR for such loss. In the event the OWNER is damaged in the course of the work by the act, negligence, omission, mistake or default of the CONTRACTOR, or should the CONTRACTOR unreasonably delay the progress of the work being done by others on the job so as to cause loss for which the OWNER becomes liable, then the CONTRACTOR shall reimburse the OWNER for such loss.
- 3.09 **PROTECTION AGAINST ACCIDENT TO EMPLOYEES AND THE PUBLIC.** The CONTRACTOR shall at all times exercise reasonable precautions for the safety of employees and others on or near the work and shall comply with all applicable provisions of Federal, State and Municipal safety laws and building and construction codes. All machinery and equipment and other physical hazards shall be guarded in accordance with the "Manual of Accident Prevention in Construction" of the Associated General Contractors of America except where incompatible with Federal State or Municipal laws or regulations.

The CONTRACTOR shall provide such machinery, guards, safe walkways, ladders, bridges, gangplanks, trench shoring and other trench safety devices and methods, and other required safety devices. The safety precautions actually taken and their adequacy shall be the sole responsibility of the CONTRACTOR, acting at his discretion as an independent contractor.

- 3.10 PERFORMANCE AND PAYMENT BONDS. Unless otherwise specified, it is further agreed by the parties to this contract that the CONTRACTOR will execute separate performance and payment bonds, each in the sum of one hundred (100) percent of the total contract price, in standard forms for this purpose, guaranteeing faithful performance of the work and the fulfillment of any guarantees required, and further guaranteeing payment to all persons supplying labor and materials or furnishing him any equipment in the execution of the Contract, and that CONTRACTOR will perform all necessary repairs, corrections and adjustments that may be required to the work during the one year period immediately following the date of final acceptance, and it is agreed that this Contract shall not be in effect until such performance and payment bonds are furnished and approved by the OWNER.

Unless otherwise approved in writing by the OWNER, the surety company underwriting the bonds shall be acceptable according to the latest list of companies holding certificates of authority from the Secretary of the Treasury of the United States.

Unless otherwise specified, the cost of the premium for the performance and payment bonds shall be included in the CONTRACTOR'S proposal.

- 3.11 LOSSES FROM NATURAL CAUSES. Unless otherwise specified, all loss or damage to the CONTRACTOR arising out of the nature of the work to be done, or from the action of the elements, or from any unforeseen circumstances in the prosecution of the same, or from unusual obstructions or difficulties which may be encountered in the prosecution of the work, shall be sustained and borne by the CONTRACTOR at his own cost and expense.

- 3.12 PROTECTION OF ADJOINING PROPERTY. The said CONTRACTOR shall take proper means to protect the property on which the work is performed and all adjacent or adjoining property or properties in any way encountered, which might be injured or seriously affected by any process of construction to be undertaken under this agreement, from any damage or injury by reason of said process of construction; and he shall be liable for any and all claims for such damage on account of his failure to fully protect all properties. The CONTRACTOR agrees to indemnify, save and hold harmless the OWNER and ENGINEER against any claim or claims for damages due to any injury to property on which the work is to be performed and any adjacent or adjoining property, arising or growing out of the performance of the contract; but any such indemnity shall not apply to any claim of any kind arising out of the existence or character of the work if performed in accordance with the Contract Documents.

- 3.13 PROTECTION AGAINST CLAIMS OF SUB-CONTRACTORS, LABORERS, MATERIALMEN AND FURNISHERS OF MACHINERY, EQUIPMENT AND SUPPLIES. The CONTRACTOR agrees that he will indemnify and save the OWNER and ENGINEER harmless from all claims growing out of the lawful demands of sub-contractors, laborers, workmen, mechanics, materialmen and furnishers of machinery and parts thereof, equipment, power tools, and all supplies, including commissary, incurred in the furtherance of the performance of this contract. When so desired by the OWNER, the CONTRACTOR shall furnish satisfactory evidence that all obligations of the nature hereinabove designated have been paid, and discharged or waived. If the CONTRACTOR fails to do so, then the OWNER may at the option of the CONTRACTOR either pay directly any unpaid bills, of which the OWNER has written notice, or withhold from the CONTRACTOR'S unpaid compensation a sum of money deemed reasonably sufficient to liquidate any and all such lawful claims until satisfactory evidence is furnished that all liabilities have been fully discharged, whereupon payments to the CONTRACTOR shall be resumed in full in accordance with the terms of this contract, but in no event shall the provisions of this sentence be construed to impose any obligation upon the OWNER by either the CONTRACTOR or his Surety.

- 3.14 PROTECTION AGAINST ROYALTIES OR PATENTED INVENTION. The CONTRACTOR shall pay all royalties and license fees and shall provide for the use of any design, device, material or process covered by letters patent or copyright by suitable legal agreement with the patentee or owner. The CONTRACTOR shall defend all suits or claims for infringement of patent or copyright rights and shall indemnify and save the OWNER and ENGINEER harmless from any loss on account thereof, except that the OWNER shall



defend all such suits and claims and shall be responsible for all such loss when a particular design, device, material or process or the product of a particular manufacturer or manufacturers is specified by the OWNER, provided, however, if choice of alternative design, device, material or process is allowed to the CONTRACTOR, then the CONTRACTOR shall indemnify and save the OWNER harmless from any loss on account thereof. If the material or process specified or required by the OWNER is an infringement, the CONTRACTOR shall be responsible for such loss unless he promptly gives such information to the OWNER.

- 3.15 LAWS AND ORDINANCES. The CONTRACTOR shall at all times observe and comply with all Federal, State and local laws, ordinances and regulations, which in any manner affect the contract or the work, and shall indemnify and save harmless the OWNER and ENGINEER against any claim arising from the violation of any such laws, ordinances, and regulations whether by the CONTRACTOR or his employees, except where such violations are called for by the provisions of the Contract Documents. If the CONTRACTOR observes that the plans and specifications are at variance therewith, he shall promptly notify the ENGINEER in writing and any necessary changes shall be adjusted as provided in the contract for changes in the work. If the CONTRACTOR performs any work knowing it to be contrary to such laws, ordinances, rules and regulations, and without such notice to the ENGINEER, he shall bear all costs arising therefrom. In case the OWNER is a body politic and corporate, the law from which it derives its powers, insofar as the same regulates the objects for which, or the manners in which, or the conditions under which the OWNER may enter into contract, shall be controlling, and shall be considered as part of this contract, to the same effect as if embodied herein.
- 3.16 ASSIGNMENT AND SUBLETTING. The CONTRACTOR further agrees that he will retain personal control and will give his personal attention to the fulfillment of this contract and that he will not assign by Power of Attorney, or otherwise, or sublet said contract without the written consent of the ENGINEER, and that no part or feature of the work will be sublet to anyone objectionable to the ENGINEER or the OWNER. The CONTRACTOR further agrees that the subletting of any portion or feature of the work, or materials required in the performance of this contract, shall not relieve the CONTRACTOR from his full obligations to the OWNER, as provided by this Agreement.
- 3.17 INDEMNIFICATION. The CONTRACTOR shall defend, indemnify and hold harmless the OWNER and the ENGINEER and their respective officers, agents and employees from and against all damages, claims, losses, demands, suits, judgments and costs, including reasonable attorney's fees and expenses, arising out of, or resulting from the performance of the work, provided that any such damages, claim, loss, demand, suit, judgment, cost or expense:
- (1) Is attributable to bodily injury, sickness, disease or death or injury to or destruction of tangible property (other than the work itself) including the loss of use resulting therefrom; and,
  - (2) Is caused in whole or in part by any negligent act or omission of the CONTRACTOR, any Subcontractor, anyone directly or indirectly employed by any one of them or anyone for whose acts any of them may be liable, regardless of whether or not it is caused in part by a party indemnifiable hereunder.

The obligation of the CONTRACTOR under this Paragraph shall not extend to the liability of the ENGINEER, his agents or employees arising out of the preparation or approval of maps, drawings, reports, surveys, Change Orders, designs or specifications, or of the failure to give directions or instructions by the ENGINEER, his agents or employees, provided such giving or failure to give is the primary cause of the injury or damage.

- 3.18 INSURANCE. The CONTRACTOR at his own expense shall purchase, maintain and keep in force such insurance as will protect him from claims set forth below which may arise out of or result from the CONTRACTOR'S operations under the Contract, whether such operations be by himself or by any Subcontractor or by anyone directly or indirectly employed by any of them, or by anyone for whose acts any of them may be liable:
- (1) Workmen's compensation claims, disability benefits and other similar employee benefit acts;

- (2) Claims for damages because of bodily injury, occupational sickness or disease, or death of his employees, and claims insured by usual bodily injury liability coverages;
- (3) Claims for damages because of bodily injury, sickness or disease, or death of any person other than his employees, and claims insured by usual bodily injury coverages; and
- (4) Claims for damages because of injury to or destruction of tangible property, including loss of use resulting therefrom.

3.19 CERTIFICATE OF INSURANCE. Before commencing any of the work, CONTRACTOR shall file with the OWNER valid Certificates of Insurance acceptable to the OWNER and the ENGINEER. Such Certificates shall contain a provision that coverages afforded under the policies will not be canceled until at least fifteen days prior written notice has been given to the OWNER.

The CONTRACTOR shall also file with the, OWNER valid Certificates of Insurance covering all subcontractors.

#### 4. PROSECUTION AND PROGRESS

4.01 TIME AND ORDER OF COMPLETION. It is the meaning and intent of this contract, unless otherwise herein specifically provided, that the CONTRACTOR shall be allowed to prosecute his work at such times and seasons, in such order of precedence, and in such manner as shall be most conducive to economy of construction: provided, however, that the order and the time of prosecution shall be such that the work shall be substantially completed as a whole and in part, in accordance with this contract, the plans and specifications, and within the time of completion designated in the Proposal; provided, also, that when the OWNER is having other work done, either by contract or by his own force, the ENGINEER may direct the time and manner of constructing the work done under this contract, so that conflict will be avoided and the construction of the various works being done for the OWNER shall be harmonized.

The CONTRACTOR shall submit, at such times as may reasonably be requested by the ENGINEER, schedules which shall show the order in which the CONTRACTOR will start the several parts of the work, and estimated dates of completion of the several parts.

4.02 EXTENSION OF TIME. Should the CONTRACTOR be delayed in the completion of the work by any act or neglect of the OWNER or ENGINEER, or of any employee of either, or by other contractors employed by the OWNER, or by changes ordered in the work, or by strikes, lockouts, fires, and unusual delays by common carriers, or unavoidable cause or causes beyond the CONTRACTOR'S control, or by any cause which the ENGINEER shall decide justifies the delay, then an extension of time shall be allowed for completing the work, sufficient to compensate for the delay, the amount of the extension to be determined by the ENGINEER, provided, however, that the CONTRACTOR shall give the ENGINEER prompt notice in writing of the cause of such delay.

4.03 HINDRANCES AND DELAYS. No claims shall be made by the CONTRACTOR for damages resulting from hindrances or delays from any cause (except where the work is stopped by order of the OWNER) during the progress of any portion of the work embraced in this contract. In case said work shall be stopped by the act of the OWNER, then such expense as in the judgment of the ENGINEER is caused by such stoppage of said work shall be paid by the OWNER to the CONTRACTOR.

#### 5. MEASUREMENT AND PAYMENT

5.01 QUANTITIES AND MEASUREMENTS. No extra or customary measurements of any kind will be allowed, but the actual measured and/or computed length, area, solid contents, number and weight only shall be considered, unless otherwise specifically provided.

5.02 ESTIMATED QUANTITIES. This agreement, including the specifications, plans and estimate, is intended to show clearly all work to be done and material to be furnished hereunder. Where the estimated quantities are shown for the various classes of work to be done and material to be furnished under this

contract, they are approximate and are to be used only as a basis for estimating the probable cost of the work and for comparing the proposals offered for the work. It is understood and agreed that the actual amount of work to be done and material to be furnished under this contract may differ somewhat from these estimates, and that where the basis for payment under this contract is the unit price method, payment shall be for the actual amount of such work done and the material furnished.

Where payment is based on the unit price method, the CONTRACTOR agrees that he will make no claim for damages, anticipated profits or otherwise on account of any differences which may be found between the quantities of work actually done, the material actually furnished under this contract and the estimated quantities contemplated and contained in the proposal; provided, however, that in case the actual quantity of any major item should become as much as 20% more than, or 20% less than the estimated or contemplated quantity for such items, then either party to this Agreement, upon demand, shall be entitled to a revised consideration upon the portion of the work above or below 20% of the estimated quantity.

A 'Major Item' shall be construed to be any individual bid item incurred in the proposal that has a total cost equal to or greater than five (5) per cent of the total contract cost, computed on the basis of the proposal quantities and the contract unit prices.

Any revised consideration is to be determined by agreement between the parties, otherwise by the terms of this agreement as provided under "Extra Work."

5.03 PRICE OF WORK In consideration of the furnishing of all the necessary labor, equipment and material, and the completion of all work by the CONTRACTOR, and on the completion of all work and of the delivery of all material embraced in this contract in full conformity with the specifications and stipulations herein contained, the OWNER agrees to pay the CONTRACTOR the prices set forth in the proposal hereto attached, which has been made a part of this contract. The CONTRACTOR hereby agrees to receive such prices in full for furnishing all material and all labor required for the aforesaid work, also for all expense incurred by him, and for well and truly performing the same and the whole thereof in the manner and according to this Agreement.

5.04 PARTIAL PAYMENTS. On or before the 5th day of each month, the CONTRACTOR shall prepare and submit to the ENGINEER for approval or modification a statement showing as completely as practicable the total value of the work done by the CONTRACTOR up to and including the last day of the preceding month: said statement shall also include the value of all sound materials delivered on the site of the work that are to be fabricated into the work.

Payment for materials delivered to the site for use in the work does not relieve the CONTRACTOR of the responsibility to protect the materials from loss, theft, damage, vandalism, or deterioration, and does not relieve the CONTRACTOR of the responsibility to replace any materials should such occur. Once delivered and paid for, materials may not be removed from the site without the written permission of the ENGINEER.

The OWNER shall then pay the CONTRACTOR on or before the last day of the current month the total amount of the approved statement, less 10 per cent of the amount thereof, and all further sums that may be retained by the OWNER under the terms of this Agreement. It is understood, however, that in case the whole work be near to completion and some unexpected and unusual delay occurs due to no fault or neglect on the part of the CONTRACTOR, the OWNER may, upon written recommendation of the ENGINEER, pay a reasonable and equitable portion of the retained percentage to the CONTRACTOR, or the CONTRACTOR at the OWNER'S option, may be relieved of the obligation to fully complete the work and, thereupon, the CONTRACTOR shall receive payment of the balance due him under the contract subject only to the conditions stated under "Final Payment."

5.05 USE OF COMPLETED PORTIONS. The OWNER shall have the right to take possession of and use any completed or partially completed portions of the work, notwithstanding the time for completing the entire work or such portions may not have expired but such taking possession and use shall not be deemed an acceptance of any work not completed in accordance with the Contract Documents. If such prior use increases the cost of, or delays the work, the CONTRACTOR shall be entitled to such extra compensation, or extension of time, or both as the ENGINEER may determine.

The CONTRACTOR shall notify the ENGINEER when, in the CONTRACTOR'S opinion, the contract is 'substantially completed' and when so notifying the ENGINEER, the CONTRACTOR shall furnish to the ENGINEER in writing a detailed list of unfinished work. The ENGINEER will review the CONTRACTOR'S list of unfinished work and will add thereto such items as the CONTRACTOR has failed to include. The 'substantial completion' of the structure or facility shall not excuse the CONTRACTOR from performing all of the work undertaken, whether of a minor or major nature, and thereby completing the structure or facility in accordance with the Contract Documents.

- 5.06 FINAL COMPLETION AND ACCEPTANCE. Within ten (10) days after the CONTRACTOR has given the ENGINEER written notice that the work has been completed, or substantially completed, the ENGINEER written notice that the work has been completed, or substantially completed, the ENGINEER and the OWNER shall inspect the work and within said time, if the work be found to be completed or substantially completed in accordance with the Contract Documents, the ENGINEER shall issue to the OWNER and the CONTRACTOR his Certificate of Completion, and thereupon it shall be the duty of the OWNER within ten (10) days to issue a Certificate of Acceptance of the work to the CONTRACTOR or to advise the CONTRACTOR in writing of the reason for non-acceptance.
- 5.07 FINAL PAYMENT. Upon the issuance of the Certificate of Completion, the ENGINEER shall proceed to make final measurements and prepare final statement of the value of all work performed and materials furnished under the terms of the agreement and shall certify same to the OWNER, who shall pay to the CONTRACTOR on or after the 30th day, and before the 35th day, after the date of the Certificate of Completion, the balance due the CONTRACTOR under the terms of this Agreement, provided he has fully performed his contractual obligations under the terms of this contract; and said payment shall become due in any event upon said performance by the CONTRACTOR. Neither the Certificate of Acceptance nor the final payment, nor any provision in the Contract Documents, shall relieve the CONTRACTOR of the obligation for fulfillment of any warranty which may be required.
- 5.08 PAYMENTS WITHHELD. The OWNER may, on account of subsequently discovered evidence, withhold or nullify the whole or part of any certificate to such extent as may be necessary to protect himself from loss on account of:
- (a) Defective work not remedied.
  - (b) Claims filed or reasonable evidence indicating probable filing of claims.
  - (c) Failure of the CONTRACTOR to make payments properly to subcontractors or for material or labor.
  - (d) Damage to another contractor.
  - (e) Reasonable doubt that the work can be completed for the unpaid balance of the contract amount.
  - (f) Reasonable indication that the work will not be completed within the contract time.

When the above grounds are removed or the CONTRACTOR provides a Surety Bond satisfactory to the OWNER, which will protect the OWNER in the amount withheld, payment shall be made for amounts withheld because of them.

- 5.09 DELAYED PAYMENTS. Should the OWNER fail to make payment to the CONTRACTOR of the sum named in any partial or final statement, when payment is due, then the OWNER shall pay to the CONTRACTOR, in addition to the sum shown as due by such statement, interest thereon at the rate of six (6) per cent per annum, unless otherwise specified, from date due as provided under 'Partial payments,' and 'Final Payments,' until fully paid, which shall fully liquidate any injury to the CONTRACTOR growing out of such delay in payment, but the right is expressly reserved to the CONTRACTOR in the event payments be not promptly made, as provided under 'Partial Payments,' to at any time thereafter treat the contract as abandoned by the OWNER and recover compensation, as provided under 'Abandonment of Contract,' unless such payments are withheld in accordance with the provisions of 'Payments Withheld.'

## 6. EXTRA WORK AND CLAIMS

- 6.01 CHANGE ORDERS: Without invalidating this Agreement, the OWNER may, at any time or from time to time, order additions, deletions or revisions to the work; such changes will be authorized by Change Order to be prepared by the ENGINEER for execution by the OWNER and the CONTRACTOR. The Change

Order shall set forth the basis for any change in contract price, as hereinafter set forth for Extra Work, and any change in contract time which may result from the change.

In the event the CONTRACTOR shall refuse to execute a Change Order which has been prepared by the ENGINEER and executed by the OWNER, the ENGINEER may in writing instruct the CONTRACTOR to proceed with the work as set forth in the Change Order and the CONTRACTOR may make claim against the OWNER for Extra Work involved therein, as hereinafter provided.

- 6.02 MINOR CHANGES: The ENGINEER may authorize minor changes in the work not inconsistent with the overall intent of the Contract Documents and not involving an increase in Contract Price, If the CONTRACTOR believes that any minor change or alteration authorized by the ENGINEER involves Extra Work and entitles him to an increase in the Contract Price, the CONTRACTOR shall make written request to the ENGINEER for a written Field Order.

In such case, the CONTRACTOR by copy of his communication to the ENGINEER or otherwise in writing shall advise the OWNER of his request to the ENGINEER for a written Field Order and that the work involved may result in an increase in the Contract Price.

Any request by the CONTRACTOR for a change in Contract Price shall be made prior to beginning the work covered by the proposed change.

- 6.03 EXTRA WORK. It is agreed that the basis of compensation to the CONTRACTOR for work either added or deleted by a Change Order or for which a claim for Extra Work is made shall be determined by one or more of the following methods:

- Method (A)- By agreed unit prices: or
- Method (B)- By agreed lump sum: or
- Method (C)- If neither Method (A) nor Method (B) be agreed upon before the Extra Work is commenced, then the CONTRACTOR shall be paid the 'actual field cost' of the work, plus fifteen (15) percent.

In the event said Extra Work be performed and paid for under Method (C), then the provisions of paragraph shall apply and the 'actual field cost' is hereby defined to include the cost to the CONTRACTOR of all workmen, such as foremen, timekeepers, mechanics and laborers, and materials, supplies, trucks, rentals on machinery and equipment, for the time actually employed or used on such Extra Work, plus actual transportation charges necessarily incurred, together with all power, fuel lubricants, water and similar operating expenses incurred directly on account of such extra work, including social security, fringe benefits and payroll taxes, and, a rateable proportion of premiums on Performance and Payment Bonds and Maintenance Bonds, Public Liability and Property Damage and Workmen's Compensation, and all other insurance as may be required by any law or ordinance, or directed by the OWNER, or by them agreed to. The ENGINEER may direct the form in which accounts of the 'actual field cost' shall be kept and the records of these accounts shall be made available to the ENGINEER. The ENGINEER or OWNER may also specify in writing, before the work commences, the method of doing the work and the type and kind of machinery and equipment to be used; otherwise these matters shall be determined by the CONTRACTOR. Unless otherwise agreed upon, the prices for the use of machinery and equipment shall be determined by using 100 percent, unless otherwise specified, of the latest schedule of Equipment Ownership Expense adopted by the Associated General Contractors of America. Where practicable, the terms and prices for the use of machinery and equipment shall be incorporated into the Written Extra Work Order. The fifteen (15) percent of the 'actual field cost' to be paid the CONTRACTOR shall cover and compensate him for his profit, overhead, general superintendence and field office expense, and all other elements of cost and expense not embraced within the 'actual field cost' as herein defined, save that where the CONTRACTOR'S Field Office must be maintained exclusively on account of such Extra Work; then the cost to maintain and operate the same shall be included in the 'actual field cost.'

No claim for Extra Work of any kind will be allowed unless ordered in writing by the ENGINEER. In case any orders or instructions, either oral or written, appear to the CONTRACTOR to involve Extra Work for which he should receive compensation or an adjustment in the construction time, he shall make written request to the ENGINEER for written order authorizing such Extra Work. Should a difference of opinion arise as to what does or does not constitute Extra Work, or as to the payment therefor, and the

ENGINEER insists upon its performance, the CONTRACTOR shall proceed with the work after making written request for written order and shall keep an accurate account of the 'actual field cost' thereof, as provided under Method (C). The CONTRACTOR will thereby preserve the right to submit the matter of payment to arbitration, as herein below provided.

6.04 TIME OF FILING CLAIMS. It is further agreed by both parties hereto that all questions of dispute or adjustment presented by the CONTRACTOR shall be in writing filed with the ENGINEER within thirty (30) days after the ENGINEER has given any directions, order or instruction to which the CONTRACTOR desires to take exception. The ENGINEER shall reply within thirty (30) days to such written exceptions by the CONTRACTOR and render his final decision in writing. In case the CONTRACTOR should appeal from the ENGINEER'S decision, any demand for arbitration shall be filed with the ENGINEER and the OWNER in writing within ten (10) days after the date of delivery to CONTRACTOR of the ENGINEER'S final decision. It is further agreed that final acceptance of the work by the OWNER and the acceptance by the CONTRACTOR of the final payment shall be a bar to any claims by either party, except where noted otherwise in the Contract Documents.

6.05 ARBITRATION. All questions of dispute under this Agreement shall be submitted to arbitration at the request of either party to the dispute. The parties may agree upon one arbiter, otherwise, there shall be three, one named in writing by each party, and the third chosen by the two arbiters so selected; or if the arbiters fail to select a third within ten (10) days, he shall be chosen by a district Judge serving the County in which the major Portion of the project is located, unless otherwise specified. Should the party demanding arbitration fail to name an arbiter within ten (10) days of the demand, his right to arbitrate shall lapse, and the decision of the ENGINEER shall be final and binding on him. Should the other party fail to choose an arbiter within ten (10) days, the ENGINEER shall appoint such arbiter. Should either party refuse or neglect to supply the arbiters with any papers or information demanded in writing, the arbiters are empowered by both parties to take ex parte proceedings.

The arbiters shall act with promptness. The decision of any two shall be binding on both parties to the contract. The decision of the arbiters upon any question submitted to arbitration under this contract shall be a condition precedent to any right of legal action. The decision of the arbiter or arbiters may be filed in court to carry it into effect.

The arbiters, if they deem the case demands it, are authorized to award the party whose contention is sustained, such sums as they deem proper for the time, expense and trouble incident to the appeal, and if the appeal was taken without reasonable cause, they may award damages for any delay occasioned thereby. The arbiters shall fix their own compensation, unless otherwise provided by agreement, and shall assess the cost and charges of the arbitration upon either or both parties. The award of the arbiters must be made in writing.

## 7. ABANDONMENT OF CONTRACT

7.01 ABANDONMENT BY CONTRACTOR. In case the CONTRACTOR should abandon and fail or refuse to resume work within ten (10) days after written notification from the OWNER, or the ENGINEER, or if the CONTRACTOR fails to comply with the orders of the ENGINEER, when such orders are consistent with the Contract Documents then, and in that case, where performance and payment bonds exist, the Sureties on these bonds shall be notified in writing and directed to complete the work, and a copy of said notice shall be delivered to the CONTRACTOR.

After receiving said notice of abandonment the CONTRACTOR shall not remove from the work any machinery, equipment, tools, materials or supplies then on the job, but the same, together with any materials and equipment under contract for the work, may be held for use on the work by the OWNER or the Surety on the performance bond, or another contractor in completion of the work; and the CONTRACTOR shall not receive any rental or credit therefor (except when used in connection with Extra Work, where credit shall be allowed as provided for under Section 6, Extra Work and Claims), it being understood that the use of such equipment and materials will ultimately reduce the cost to complete the work and be reflected in final settlement.

Where there is no performance bond provided or in case the Surety should fail to commence compliance with the notice for completion herein before provided for, within ten (10) days of service of such notice, then the OWNER may provide for the completion of the work in either of the following elective manners:

- 7.01.1 The OWNER may thereupon employ such force of workers and use such machinery, equipment, tools, materials, and supplies as said owner may deem necessary to complete the work and charge the expense of such labor, machinery, equipment, tools, materials and supplies to said CONTRACTOR, and expense so charged shall be deducted and paid by the OWNER out of such moneys as may be due, or that may thereafter at any time become due to the CONTRACTOR under and by virtue of this Agreement. In case such expense is less than the sum which would have been payable under this contract, if the same had been completed by the CONTRACTOR, they said CONTRACTOR shall receive the difference. In case such expense is greater than the sum which would have been payable under this contract, if the same had been completed by said CONTRACTOR, then the CONTRACTOR and/or his Surety shall pay the amount of such excess to the OWNER; or
- 7.01.2 The OWNER under sealed bids, after five (5) days notice published one or more times in a newspaper having general circulation in the county of the location of the work, may let the contract for the completion of the work under substantially the same terms and conditions which are provided in this contract. In case any increase in cost to the OWNER under the new contract as compared to what would have been the cost under this contract, such increase shall be charged to the CONTRACTOR and the Surety shall be and remain bound therefor. However, should the cost to complete any such new contract prove to be less than what would have been the cost to complete under this contract, the CONTRACTOR and/or his Surety shall be credited therewith.

When the work shall have been substantially completed the CONTRACTOR and his Surety shall be so notified and Certificates of Completion and Acceptance, as provided in Paragraph 5.06 hereinabove, shall be issued. A complete itemized statement of the contract accounts, certified to by the ENGINEER as being correct, shall then be prepared and delivered to the CONTRACTOR and his Surety, whereupon the CONTRACTOR and/or his Surety, or the OWNER as the case may be, shall pay the balance due as reflected by said statement, within fifteen (15) days after the date of such Certificate of Completion.

In the event the statement of accounts shows that the cost to complete the work is less than that which would have been the cost to the OWNER had the work been completed by the CONTRACTOR under the terms of this contract; or when the CONTRACTOR and/or his Surety shall pay the balance shown to be due by them to the OWNER, then all machinery, equipment, tools, materials or supplies left on the site of the work shall be turned over to the CONTRACTOR and/or his Surety. Should the cost to complete the work exceed the contract price, and the CONTRACTOR and/or his Surety fail to pay the amount due the OWNER within the time designated hereinabove, and there remains any machinery, equipment, tools, materials or supplies on the site of the work, notice thereof, together with an itemized list of such equipment and materials, shall be mailed to the CONTRACTOR and his Surety at the respective addresses designated in this contract, provided, however, that actual written notice given in any manner will satisfy this condition. After mailing, or other giving of such notice, such property shall be held at the risk of the CONTRACTOR and his Surety subject only to the duty of the OWNER to exercise ordinary care to protect such property. After fifteen (15) days from the date of said notice the OWNER may sell such machinery, equipment, tools, materials or supplies and apply the net sum derived from such sale to the credit of the CONTRACTOR and his Surety. Such sale may be made at either public or private sale, with or without notice, as the OWNER may elect. The OWNER shall release any machinery, equipment, tools, materials, or supplies, which remain on the work, and belong to persons other than the CONTRACTOR or his Surety, to their proper owners. The books on all operations provided herein shall be open to the CONTRACTOR and his Surety.

- 7.02 ABANDONMENT BY OWNER. In case the OWNER shall fail to comply with the terms of this contract, and should fail or refuse to comply with said terms within ten (10) days after written notification by the CONTRACTOR, then the CONTRACTOR may suspend or wholly abandon the work, and may remove therefrom all machinery, tools and equipment, and all materials on the site of work that have not been included in payments to the CONTRACTOR and have not been wrought into the work. And thereupon the

ENGINEER shall make an estimate of the total amount earned by the CONTRACTOR, which estimate shall include the value of all work actually completed by said CONTRACTOR (at the prices stated in the attached proposal work where unit prices are used), the value of all partially completed work at a fair and equitable price, and the amount of all Extra Work performed at the prices agreed upon, or provided for by the terms of this contract, and a reasonable sum to cover the cost of any provisions made by the CONTRACTOR to carry the whole work to completion and which cannot be utilized. The ENGINEER shall then make a final statement of the balance due the CONTRACTOR by deducting from the above estimate all previous payments by the OWNER and all other sums that may be retained by the OWNER under the terms of this Agreement and shall certify same to the OWNER who shall pay to the CONTRACTOR on or before thirty (30) days after the date of the notification by the CONTRACTOR the balance shown by said final statement as due the CONTRACTOR, under the terms of this Agreement.



**CONTRACT CHANGE ORDER**

ORDER NO.
DATE
STATE
COUNTY

CONTRACT FOR

OWNER

To \_\_\_\_\_  
 (Contractor)

You are hereby requested to comply with the following changes from the original contract plans and specifications:

Description of Changes (Supplemental Plans and Specifications Attached)	DECREASE in Contract Price	INCREASE in Contract Price
	\$	\$
TOTALS	\$	\$
NET CHANGE IN CONTRACT PRICE	\$	\$

JUSTIFICATION:

The amount of the Contract will be (Decreased) (Increased) By The Sum Of: \_\_\_\_\_  
 \_\_\_\_\_ Dollars (\$ \_\_\_\_\_).

The Contract Total Including this and previous Change Orders Will Be: \_\_\_\_\_  
 \_\_\_\_\_ Dollars (\$ \_\_\_\_\_).

The Contract Period Provided for Completion Will BE (Increased) (Decreased) (Unchanged): \_\_\_\_\_ Days.

This document will become a supplement to the contract and all provisions will apply hereto

Requested	_____ (Owner)	_____ (Date)
Recommended	_____ (Owner's Architect/Engineer)	_____ (Date)
Accepted	_____ (Contractor)	_____ (Date)
Approved By FmHA	_____ (Name and Title)	_____ (Date)

This information will be used as a record of any changes to the original construction contract.

## SUPPLEMENTAL GENERAL CONDITIONS

1. Supplemental General Conditions: These Supplemental Conditions amend and supplement the "General Conditions of Agreement" and shall govern in the event of any conflict with the General Conditions. The Engineer's decision shall be final as to interpretation and/or conflict between any of the reference specifications and standards contained herein.
  
2. Additional Definitions: Wherever the following terms are used in these specifications, their meaning shall be construed in accordance with the definitions listed below.
  - a. Engineer: McGhee Engineering, Inc., P.O. Box 267, 202 Ewing Street, Guthrie, Kentucky 42234, telephone (270) 483-9985.
  - b. Inspector: Representative of the Engineer or Owner stationed at, or visiting the site of the work to secure conformity with the Plans and Specifications, to record the work performed by the Contractor and to serve in such other capacities as the Engineer may direct.
  - c. Plans: All drawings adopted by the Engineer and bound herein pertaining to the work under this contract.
  - d. ASTM Specifications: Adopted by the American Society for Testing and Materials, governing the methods and procedures for manufacturing and testing materials and bearing appropriate alphabetical and numerical designations pertinent to the various items involved.
  - e. OSHA: Occupational Health and Safety Administration requirements pertaining to the project.
  
3. The following abbreviations will be used in these Specifications, the Proposal and contract:

LF or L.F.	Linear Foot
SF or S.F.	Square Foot
LS or L.S.	Lump Sum
EA or Ea	Each
SQ. IN.	Square Inch
LBS.	Pounds
LIN. IN.	Linear Inch
  
4. Public Safety: The safety of the public, protection of property, and convenience of traffic shall be of prime importance during construction. In all respects, public safety and protection of property and provisions therefor, made necessary by the work, shall be the direct responsibility of the Contractor and shall be performed at his expense.
  
5. Completion Time and Liquidated Damages: The project as indicated in the Plans and Specifications shall be completed within the number of consecutive working days stated in the Contract. Contractors shall submit any request for time extensions at the time of submission of the pay request covering the period during which the time extension is requested, and such requests shall include justification in conformance with the Contract. Failure to make timely submittal of requests for time extension shall be grounds for their denial. The times set forth in the Proposal for completion of work are an essential element of the Contract. The Contractor and Owner understand and agree that a breach of this Contract as to completion on time will cause damage to the Owner. The parties agree that for each and every calendar day the work or any portion thereof shall remain uncompleted after the expiration of the contract time limit, **two hundred fifty dollars (\$250.00) per day** will be deducted from the money due or to become due the Contractor, not as a penalty, but as liquidated damages and added expense of engineering and overhead.
  
6. Contractor's Warranty: The Contractor shall guarantee that all work performed under this Contract is new and free of faulty materials in every particular, and free of faulty workmanship, and he does hereby agree to maintain, replace or re-execute without additional cost to the Owner such work found to be

unsatisfactory and to make good all damage to his, or work by others affected by this Contract as a result of improper workmanship and materials or due to such required replacement or re-execution.

The Contractor shall warrant all such work for a period of one (1) year from the date of acceptance of all work performed under this Contract. A "Final Certificate" will be issued by the Engineer, as evidence. Neither the "Final Certificate," nor payment, nor any provisions in the Contract Documents shall relieve the Contractor of the guarantee or maintenance provisions, or his responsibility for neglect or the replacement of faulty materials, or workmanship, or any other items of defect during the warranty period.

7. **Safety:** The Contractor shall be responsible for the safety of himself, his employees and other persons, as well as for the protection of the safety of the improvements being erected and the property of himself or any other person, as a result of his operation. All work shall be done in accordance with the Occupational Safety and Health Administration regulations and all other current federal, state and local laws pertaining to occupational safety, health and welfare. All monitoring and testing required to assure compliance with such requirements shall be the responsibility of the Contractor.
8. **Contractor's Responsibility for Materials and Equipment:** The Contractor shall assume full responsibility for all supplies, materials and equipment furnished or installed by him for the work he contracts to do, whether furnished by him or by other parties, until the same shall have been installed and finally tested and accepted by the Engineer. The Contractor shall, therefore, insure such property against loss or damage while stored at the site of the work.
9. **Permits, Licenses and Laws:** The Contractor shall obtain, at his own expense, all necessary permits and licenses from the proper authorities and shall give all notice required by law or ordinance and shall pay all fees and charges incidental to the due and lawful prosecution of the work and shall comply with all laws, ordinances and regulations relating thereto. Contractor shall obtain necessary building permits; however, there shall be no fees charged to the Contractor by the Owner.

The Owner shall not be responsible to the Contractor for expenses incurred while performing the work under this contract due to the requirements and conditions imposed on the Contractor by any governmental agencies. The Contractor shall investigate with said government as to the requirements and conditions to be imposed.

Copies of said permits, licenses, authorizations or regulations shall be filed with the Owner through the Engineer or his representative. In the event that any work to be performed by the Contractor under the above mentioned permits is found to be unsatisfactory and is not approved by the aforementioned governmental authorities, the cost thereof shall be charged to the Contractor and shall be withheld by the Owner from any money due to the Contractor under the subject construction contract.

10. **Labor Laws:** The Contractor shall comply with, and shall cause all subcontractors to comply with, the requirements of all applicable labor laws (hours of work, minimum wage, prevailing wage, etc.).
11. **Protection of Adjoining Property:** Special attention is called to Paragraph 3.12 of the General Conditions of Agreement. Any damage to any property of the Owner or other caused by the Contractor's operations shall be corrected at the Contractor's expense.
12. **Cleanup:** Upon completion of the work and before acceptance and final payment by the Owner, the Contractor shall remove rubbish, unused materials and temporary structures from the limits of the project and restore, in a manner acceptable to the Engineer, all property both public and private that has been damaged during prosecution of the work, and shall level and grade all portions of the work where the surface of the ground or street surface has been disturbed during construction and shall leave the site of the work in a neat and presentable condition, free from ruts and holes. Areas where vegetation is disturbed by construction shall be graded and re-seeded to the satisfaction of the Owner.

Materials associated with the project shall not be deposited on adjacent property unless prior approval has been obtained from the property owner involved.

No extra payment will be made for these cleanup requirements, its cost being included in the various unit prices bid in this proposal.

13. Resident Construction Observation: The Owner may employ the services of a resident construction observer during construction of the project. The purpose of the resident construction observer is to provide additional assurances to the owner as to the quality of the work and the conformance of the work to the plans and specifications. The resident construction observer is not provided to act as a supervisor of the contractor's activities, nor to take responsibility for the quality or safety of the contractor's work. Such responsibilities remain exclusively with the contractor.
14. Basis of Payment: The basis of payment for all items involved with the project will be made according to the units described in the Proposal breakdown. If there are any conflicts between the basis of payment described in the Specification and the units described in the Proposal breakdown, then the Proposal breakdown will prevail.
15. Inclement Weather: The basis of contract time is calendar days. If during the course of the project, weather conditions prevail that preclude performance of productive work for a number of days in excess of that which would normally be expected for the period, the Contractor may request a compensating time extension.
16. Insurance: The Contractor shall carry such insurance as is required to afford adequate protection to all parties affected by construction operations. Coverage limits shall not be less than the following.

General Liability	General Aggregate	\$1,000,000
	Product & Completed Operations Aggregate	\$1,000,000
	Personal & Advertising Injury	\$1,000,000
	Each Occurrence	\$1,000,000
	Fire Damage	\$100,000
	Medical Expense (per person)	\$10,000
Automotive Liability	Combined Single Limit	\$300,000
Excess Liability	Umbrella Form	\$1,000,000
Workers Compensation		Statutory Limits

In addition, the Contractor shall name the Owner and the Engineer as "also insured" in all policies. Insurance shall be continuously in force throughout the project construction. Contractor shall provide certification of coverages upon request, and update such certifications as required to remain current. Any additional insurance, bonds or other sureties required by governmental agencies, railroads, pipeline companies, utilities or others are to be provided by the Contractor as required.

END OF SECTION

SECTION 01-100

**SUMMARY OF WORK**

1.0 GENERAL

1.01 WORK INCLUDED

- A. Repair and replacement of two (2) drainage grates, surrounding pavement, and curb on Westbrooke Circle in the city limits of Pembroke, Kentucky.
- B. The Contractor shall include all materials, labor and equipment necessary for completion of the Project. The Contract Documents are intended to provide the basis for proper completion of the work suitable for the intended use of the Owner. Anything not expressly set forth but which is reasonably implied or necessary for proper performance of the Project shall be included.
- C. The following major Work items are included in the Contract:
  - 1. Removal of Existing drainage grates.
  - 2. Replacement of existing drainage grates.
  - 3. Removal of surrounding asphaltic pavement, curb, and unsuitable backfill.
  - 5. Replacement of suitable backfill, concrete curb, and surrounding pavement.

1.02 PERMITS

Obtain all permits related to or required by the Work in this Contract.

1.03 CODES

Comply with applicable codes and regulations of authorities having jurisdiction. Submit copies of inspection reports, notices, citations and similar communication to the Owner.

1.04 EXISTING CONDITIONS AND DIMENSIONS

- A. The Work in this Contract will primarily be performed along Pembroke city streets and/or State Highways.
- B. The Contractor is responsible for verifying all existing conditions, elevations, dimensions, etc., and providing his finished work to accommodate existing conditions.

2.0 CONTRACTOR'S DUTIES

2.01 Construction and Related Activities

The Contractor shall provide and pay for all labor, materials, equipment, machinery, tools, superintendence, insurance, shipping, utilities, and other costs required for a complete and functioning drainage area.

2.02 Taxes

The Contractor shall pay all required sales taxes, payroll taxes, consumer and use taxes, and other taxes relating to the work of the project.

2.03 Permits

The contractor shall secure and pay for all legally required permits, licenses and fees associated with the construction.

#### 2.04 Notices

The Contractor shall provide all required notices, including notices to utility owners of intent to excavate in the vicinity of their utilities, notices to property owners of intent to enter their property for construction purposes, notices regarding the interruption of any utility service, as well as other notices required by the plans and contract documents. **The Contractor shall provide traffic control equipment and flagman, as necessary.**

#### 2.05 Laws

Contractor shall fully comply with all applicable laws, ordinances, rules, regulations, orders and other legal requirements, and shall bear the cost of such compliance.

#### 2.06 Character of Workmen

Contractor shall employ workman and foremen with sufficient knowledge of and experience in the type of work proposed to assure satisfactory performance. Workman shall maintain a professional demeanor and appearance at all times on the project. Any workman on the project who performs work in an incompetent manner, or acts in a disorderly or intemperate manner shall be removed from the project, and may not be employed on any portion of the project unless approved by the Owner.

#### 2.07 Notice of Discrepancies

If discrepancies or ambiguities are found in the plans, specifications, contract documents, or any communication to the contractor, the contractor shall immediately notify the Engineer in writing. Do not proceed with the affected work until clarification is received.

#### 2.08 Inspection

Provide at all times, access to the work for inspection by representatives of the Owner, the Engineer, and regulatory authorities having jurisdiction over the project.

#### 2.09 Contractor's Use of Premises

Contractor shall confine his operations to public right-of-way, easements and property obtained by the Owner for construction of the project, or to areas secured by the Contractor for his use. Contractor shall take precautions to minimize disruption to existing properties.

Stored materials, regardless of their location shall be protected by the Contractor from damage, theft or degradation at all times.

#### 2.10 Existing Facilities

The existing and adjacent roadways will be in continuous operation during the construction of the Project. Contractor shall avoid disturbing existing streets, and any other utilities or structures encountered in the work, except as necessary for construction operations. Contractor shall give at least 48 hours prior notice to the Owner, or to any utility or other entity, of any necessary disruptions to service, or work affecting active lines.

#### 2.11 Partial Owner Occupancy

The Owner may, at his discretion, place into service any or all portions of the completed work prior to final completion of all work on the project. Placing a portion of the work in service before final completion does not relieve the contractor of his obligation to complete all work associated with that portion of the work (i.e. clean-up, surface restoration, etc.), to perform maintenance for the required period, or to provide warranty for that portion of the work

### 3.0 MEASUREMENT & PAYMENT

#### 3.01 General

The Westbrooke Circle Drainage Rehab Project shall be measured by percent complete of critical milestone items actually installed or delivered in accordance with the contract drawings and specifications in the completed system. Payment shall be at the lump sum basis for the items specified. Payment shall be total compensation for all materials, site preparation, and all accessories referenced by the plans and specifications, including excavation, installation, backfill and incidentals necessary for a complete and working installation, all in accordance with the plans and specifications.

END OF SECTION 01-100

SECTION 03-100

**CONCRETE FORMWORK**

1.0 GENERAL

1.01 WORK INCLUDED

- A. Formwork for cast-in-place concrete, with shoring, bracing, and anchorage.
- B. Openings for other affected work.
- C. Form accessories.
- D. Stripping forms.

1.02 RELATED WORK

- A. Section 03-210: Reinforcing Steel.

1.03 REFERENCES

- A. ACI 301 - Specifications for Structural Concrete for Buildings.
- B. ACI 347 - Recommended Practice for Concrete Formwork.
- C. PS 1 - Construction and Industrial Plywood.
- D. ACI 318 - Building Code Requirements for Reinforced Concrete.
- E. ACI 350 R - Environmental Engineering Concrete Structures.

1.04 SYSTEM DESCRIPTION

Design, engineer and construct formwork, shoring, and bracing to meet design and code requirements so that resultant concrete conforms to required shapes, lines, dimensions and tolerances.

1.05 QUALITY ASSURANCE

Construct and erect concrete formwork in accordance with ACI 301 and 347, latest revisions.

2.0 PRODUCTS

2.01 FORM MATERIALS

- A. Plywood; Douglas Fir species; medium density overlaid one side grade; sound, undamaged sheets with straight edges.
- B. Glass fiber fabric reinforced plastic forms; matched, tight fitting, stiffened to support weight of concrete without deflection detrimental to structural tolerances and appearance of finished concrete surface.
- C. Forms shall be sufficiently rigid to prevent displacement or sagging between supports and so constructed that the concrete will not be damaged by their removal. The Contractor shall be entirely responsible for their adequacy.
- D. For surfaces to be given a rubbed finish, the form surface in contact with the concrete shall be



made of heavy gage metal, new plywood (used plywood may not be used), tempered wood fiberboards with smooth surface, or similar material. Metal forms or form linings shall have square edges so that the concrete will not have fins or fluting. Forms shall not be pieced out by use of material different from those in the adjacent form or in such manner as will detract from the uniformity of the finished surface.

- E. For surfaces other than those to be given a rubbed finish, forms shall be made of wood, metal, or other acceptable material. Wooden forms shall be constructed of sound lumber or plywood of suitable dimensions, free from knotholes and loose knots. Plywood shall be reasonably good as accepted. Metal forms shall be of an acceptable type for the work involved. Edges of forms in contact with concrete shall be flush within 1/16-inch.
- F. Forms for walls, columns, or piers shall have removable panels at the bottom for cleaning, inspection, and scrubbing in of bonding grout. Forms for thin sections (such as walls or columns) of considerable height shall be arranged with suitable openings so that the concrete can be placed in a manner that will prevent segregation and accumulations of hardened concrete on the forms or reinforcement above the fresh concrete, unless special spouts are used to place concrete, and so that construction joints can be properly keyed and treated.
- G. Forms for exposed surfaces shall be built with 3/4-inch chamfer strips attached to produce smooth, straight chamfers at all sharp edges of concrete.
- H. All forms shall be oiled with an acceptable nonstaining oil or liquid form coating before reinforcement is placed.
- I. Before form material is reused, all surfaces that are in contact with the concrete shall be thoroughly cleaned, all damaged places repaired, and all projecting nails withdrawn.

## 2.02 FORMWORK ACCESSORIES

- A. Form ties to be encased in concrete shall not be made of through bolts or common wire, but shall be made and installed as to embody the following features:
  - 1. After removal of the protruding part of the tie, there shall be no metal nearer than 1 inch to the face of the concrete.
  - 2. That part of the tie which is to be removed shall be at least 1/2-inch in diameter, or if smaller, it shall be provided with a wood or metal cone 1 inch long placed against the inside of the forms. Cones shall be carefully removed from the concrete after the forms have been stripped.
  - 3. Ties that pass through walls subject to hydrostatic pressure shall be provided with acceptable water stops, such as washers, securely fastened to the ties.
- B. Form Release Agent: Colorless material which will not stain concrete, absorb moisture or impair natural bonding or color characteristics of coating intended for use on concrete. Form oil shall be placed prior to reinforcing steel when possible and surplus oil on form surfaces or reinforcing steel shall be removed.
- C. Fillets for Chamfered Corners: Wood strip type to the size and shape as shown on the Drawings (or 3/4-inch if not shown).
- D. Dovetail Anchor Slots: Minimum 10 gage thick galvanized steel; foam filled; release tape sealed slots; bent tab anchors securable to concrete formwork.
- E. Nails, spikes, lag bolts, through bolts, anchorages: Sized as required of strength and character to maintain formwork in place while placing concrete.

### 3.0 EXECUTION

#### 3.01 INSPECTION

Verify lines, levels and measurements before proceeding with formwork.

#### 3.02 PREPARATION

Earth forms not permitted except for continuous strip footings of buildings.

#### 3.03 ERECTION

- A. Provide bracing to ensure stability of formwork. Strengthen formwork liable to be overstressed by construction loads.
- B. Camber slabs and beams to achieve ACI 301 tolerances.
- C. Provide temporary ports in formwork to facilitate cleaning and inspection. Locate openings at bottom of forms to allow flushing water to drain. Close ports with tight fitting panels, flush with inside face of forms, neatly fitted so that joints will not be apparent in exposed concrete surfaces.
- D. Concrete surfaces not exposed to view shall be formed with sound tight lumber or other material producing equivalent finish.
- E. Concrete surfaces to be exposed to view shall be formed with material that is not reactive with concrete surfaces and shall be equivalent in smoothness and appearance to that produced by new plywood panels conforming to PS 1, exterior type Grade B-B.

#### 3.04 APPLICATION OF RELEASE AGENT

Apply form release agent on formwork in accordance with manufacturer's instructions. Apply prior to placing reinforcing steel, anchoring devices, and embedded items.

#### 3.05 INSERTS, EMBEDDED PARTS, AND OPENINGS

- A. Provide formed openings where required for work embedded in or passing through concrete.
- B. Coordinate work of other sections in forming and setting openings, slots, recesses, chases, sleeves, bolts, anchors, and other inserts.
- C. Install accessories in accordance with manufacturer's instructions, level and plumb. Ensure items are not disturbed during concrete placement.

#### 3.06 FORM REMOVAL

- A. Do not remove forms and bracing until concrete has sufficient strength to support its own weight and construction and design loads which may be imposed upon it. Remove load-supporting forms when concrete has attained 75 percent of required 28-day compressive strength, provided construction is reshored.
- B. Reshore structural members due to design requirements or construction conditions to permit successive construction.
- C. Remove formwork progressively so that no unbalanced loads are imposed on structure.
- D. Do not damage concrete surfaces during form removal.

3.07 CLEANING

- A. Clean forms to remove foreign matter as erection proceeds.
- B. Ensure that water and debris drain to exterior through clean out ports.
- C. During cold weather, remove ice and snow from forms. Do not use deicing salts. Do not use water to clean out completed forms unless formwork and construction proceed within heated enclosure. Use compressed air to remove foreign matter.

END OF SECTION 03-100

SECTION 03-210

**REINFORCING STEEL**

1.0 GENERAL

1.01 WORK INCLUDED

- A. Reinforcing steel.

1.02 RELATED WORK

- A. Section 03-100: Concrete Formwork.

1.03 REFERENCES

- A. ASTM A-615.
- B. ASTM A-616.
- C. ASTM A-617.
- D. ACI 351.
- E. ASTM A-120.
- F. ASTM A-185.

1.04 SUBMITTALS

- A. Shop Drawings: If requested, the Contractor shall submit a complete set of shop drawings including schedules and bending drawings for all reinforcement used in the work in accordance with the "Manual of Standard Practice for Detailing Concrete Structures" (ACI 351).

2.0 PRODUCTS

2.01 MATERIALS

- A. The minimum yield strength of the reinforcement shall be 60,000 pounds per square inch. Bar reinforcement shall conform to the requirements of ASTM A-615, A-616, or A-617. All bar reinforcement shall be deformed.
- B. Smooth dowels shall be plain steel bars conforming to ASTM A-615, Grade 40, or steel pipe conforming to ASTM A-120, Schedule 80. Pipe, if used, shall be closed flush at each end with mortar or metal or plastic cap.
- C. Welded wire fabric shall conform to ASTM 185, welded steel wire fabric for concrete reinforcement.
- D. Reinforcement supports and other accessories in contact with the forms for members which will be exposed to view in the finished work shall have approved high density polyethylene tips so that the metal portion shall be at least 1/4-inch from the form or surface. Supports for reinforcement, when in contact with the ground or stone fill, shall be precast stone concrete blocks.

## 2.02 FABRICATION

- A. Reinforcement shall be bent cold. It shall be bent accurately to the dimensions and shapes shown on the plans and to within tolerances specified in the CR51 Manual of Standard Practice.
- B. Reinforcing shall be shipped with bars of the same size and shape, fastened securely with wire and with metal identification tags giving size and mark.

## 3.0 EXECUTION

### 3.01 PLACING AND FASTENING

- A. Before being placed in position, reinforcement shall be cleaned of loose mill and rust scale, dirt and other coatings that will interfere with development of proper bond.
- B. Reinforcement shall be accurately placed in positions shown on the Drawings and firmly held in place during placement and hardening of concrete by using annealed wire ties. Bars shall be tied at all intersections except where spacing is less than 1 foot in both directions, and then alternate intersections may be tied.
- C. Distance from the forms shall be maintained by means of stays, blocks, ties, hangers or other approved supports. If fabric reinforcement is shipped in rolls, it shall be straightened into flat sheets before being placed.
- D. **Before any concrete is placed, the Engineer shall have inspected the placing of the steel reinforcement and given permission to deposit the concrete. Concrete placed in violation of this provision will be rejected and thereupon shall be removed.**
- E. Unless otherwise specified, reinforcement shall be furnished in the full lengths indicated on the Drawings. Splicing of bars, except where shown on the Drawings, will not be permitted without the approval of the Engineer. Where splices are made, they shall be staggered insofar as possible.
- F. Dowels shall be installed at right angles to construction joints and expansion joints. Dowels shall be accurately aligned parallel to the finished surface, and shall be rigidly held in place and supported during placing of the concrete. One end of dowels shall be oiled or greased and have a plastic expansion end cap.

END OF SECTION 03-210

# CONSTRUCTION PLANS

for the

## *Westbrooke Circle Drainage Repair Project*

on behalf of the

# CITY OF PEMBROKE

*Christian County, Kentucky*

VICINITY MAP

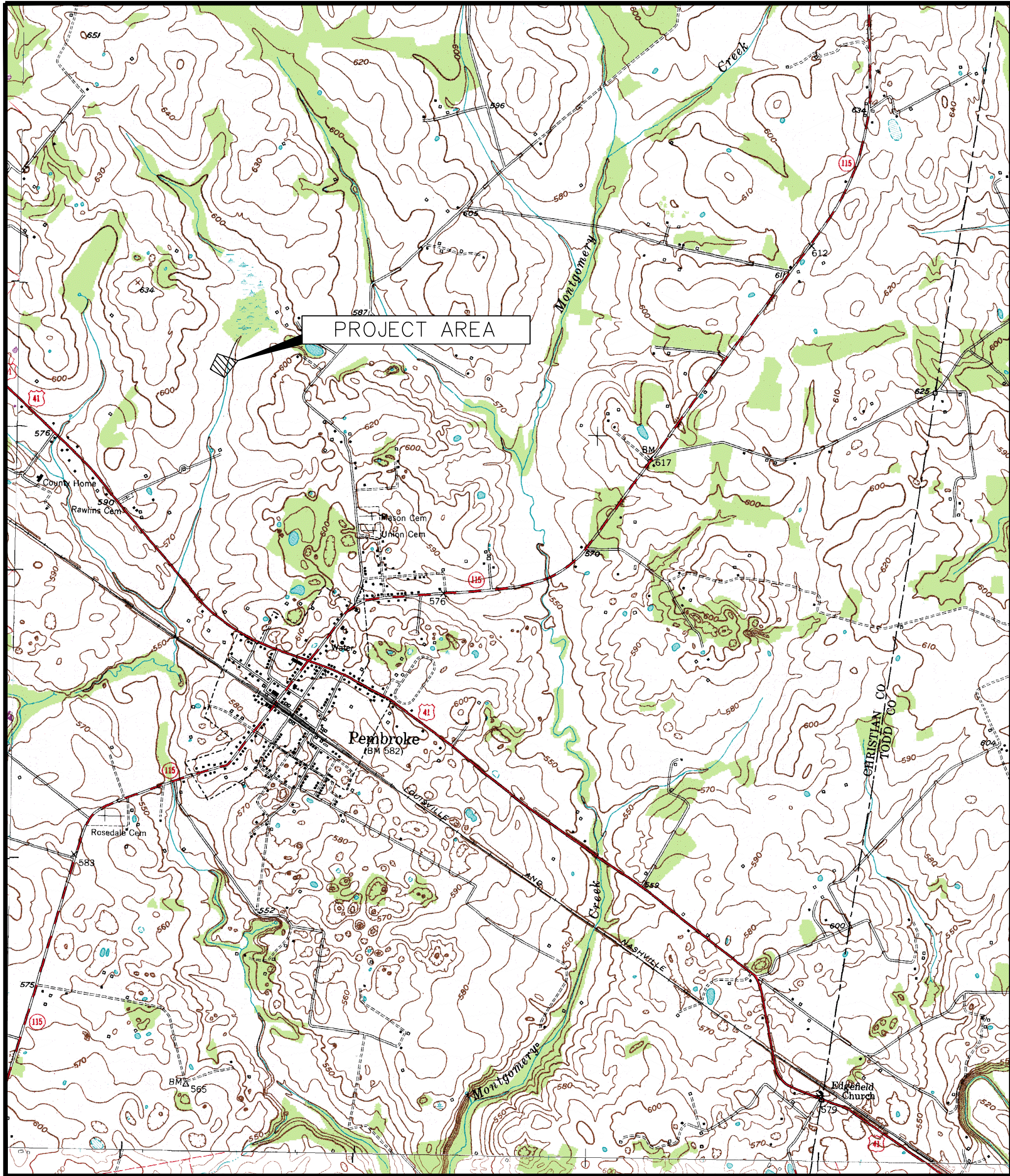

SHEET INDEX

- T-1 Title Sheet
- P-1 Location Map
- P-2 Detail Sheet

Mayor & City Council

Judy Peterson	Mayor
Jeanette Aldridge	Commissioner
Steve Pyle	Commissioner
David Rule	Commissioner
Betsy Shelton	Commissioner

Pembroke, Kentucky  
 222 S. Main Street – P.O. Box 162  
 Pembroke, Kentucky 42266  
 (270) 475-4343

Engineer

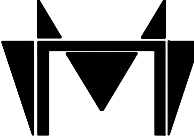
 McGhee Engineering, Inc.  
 202 Ewing St, Box 267  
 Guthrie, Kentucky 42234  
 (270) 483-9985

OCTOBER 2019

Replace existing drainage grates and frame. Sawcut to remove asphalt, curb, and unsuitable subgrade. Backfill outside of inlet box completely with concrete. Field verify new grate elevation to allow for positive drainage. Refer to details on sheet 2 of 2.

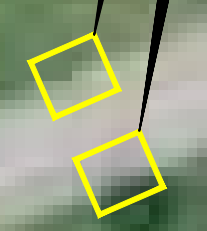

WESTBROOKE CIRCLE

WESTBROOKE CIRCLE

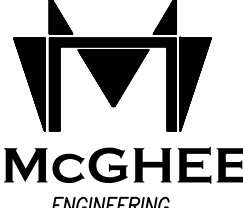
<p>Legend</p> <p> Repair Area</p>		<p>City of Pembroke</p> <p>222 S Main St Pembroke, Kentucky 42266</p> <p>Phone: (270) 475-4343</p>	
<p> <b>MCGHEE ENGINEERING, INC.</b></p> <p>Phone: (270) 483-9985 Fax: (270) 483-9986 e-mail: mmcgee@apex.net</p>		<p>202 South Ewing Street P. O. Box 267 Guthrie, Kentucky 42234</p>	
<p>Date</p> <p>10/2/2019</p>	<p>Prep. By</p> <p>K. Willis</p>	<p>Scale</p> <p>1" = 40'</p>	<p>File No.</p> <p>Sheet</p> <p>1 of 2</p>

Westbrooke Circle  
Drainage Grate Repair

**HOE-410 DRIVE OVER INLET FRAME & GRATE**

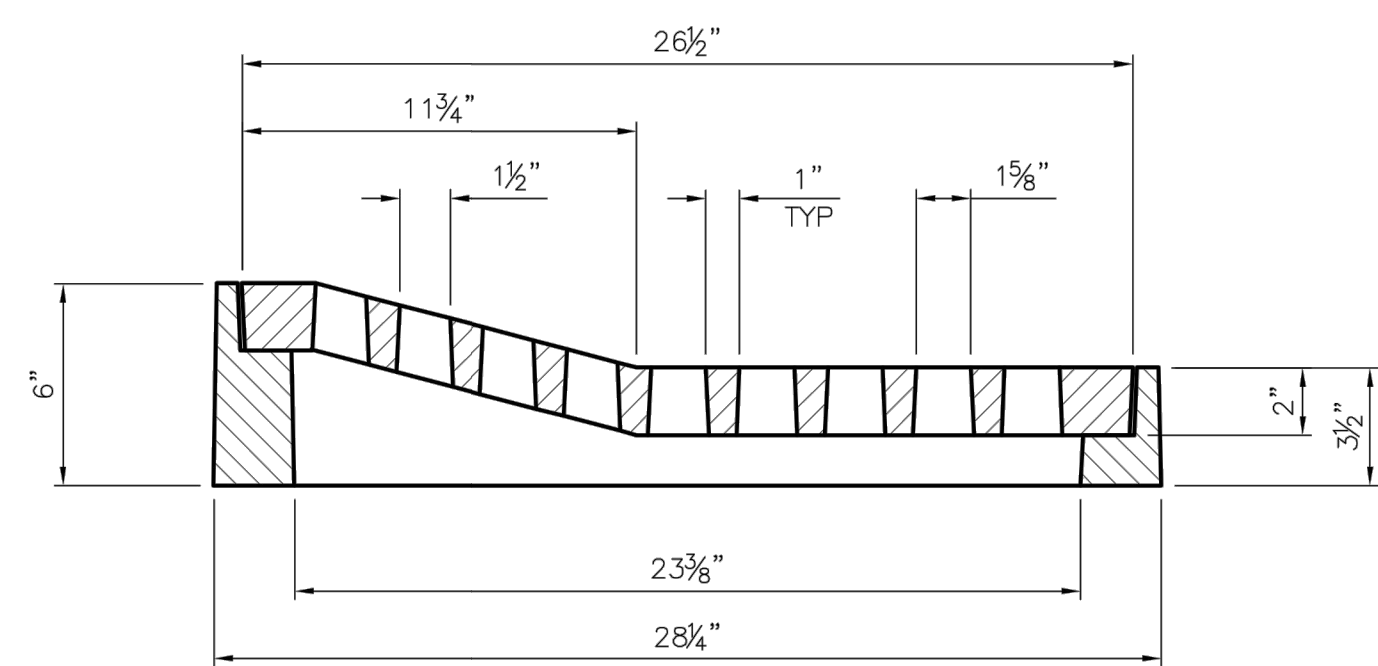
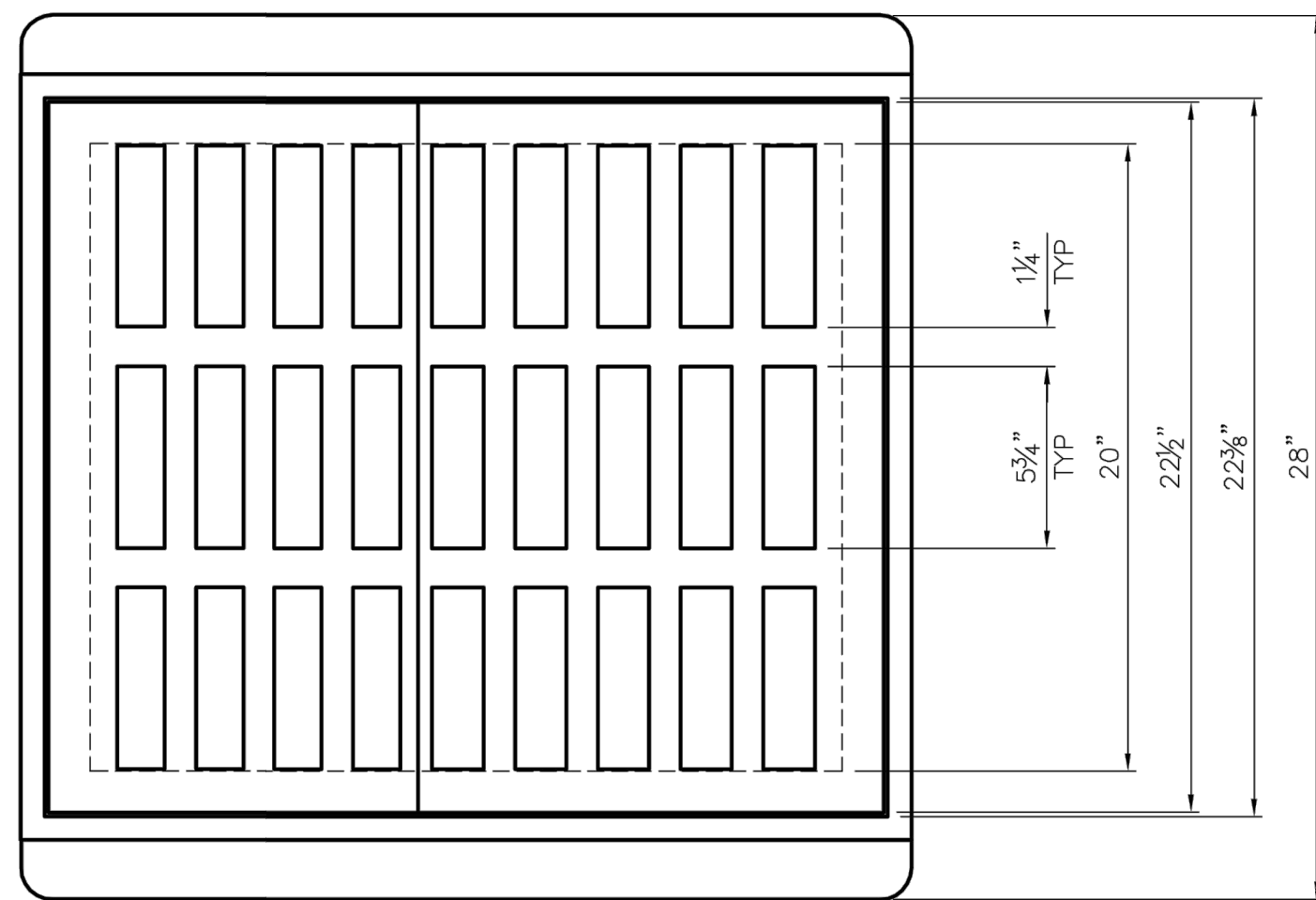

**FRAME & GRATE**

NOT TO SCALE

A  
2

NOTE: GRATE SHALL LINE UP WITH OUTER FACE OF EXISTING CURB

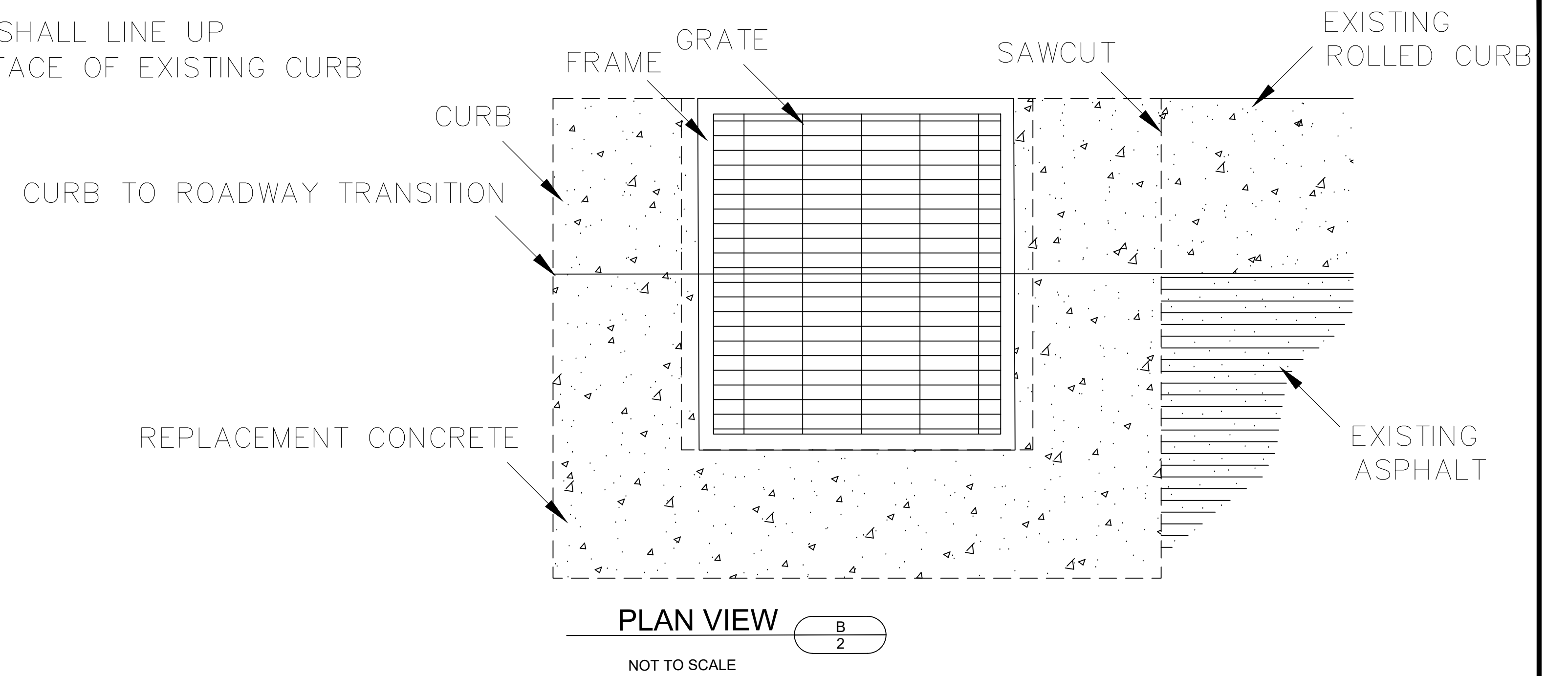

**PLAN VIEW**

NOT TO SCALE

B  
2

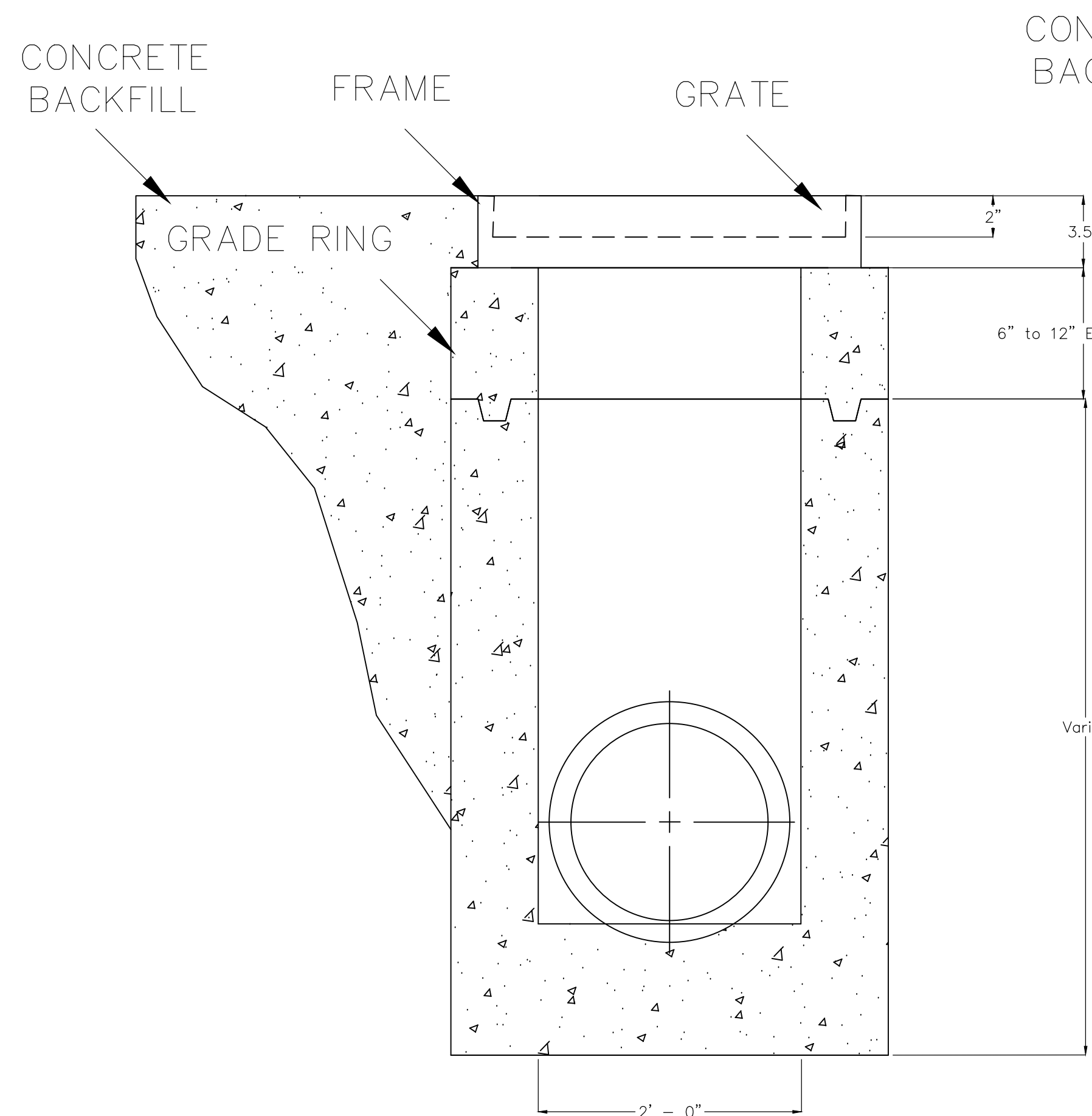

**PRECAST BOX SECTION ROAD VIEW**

NOT TO SCALE

C  
2

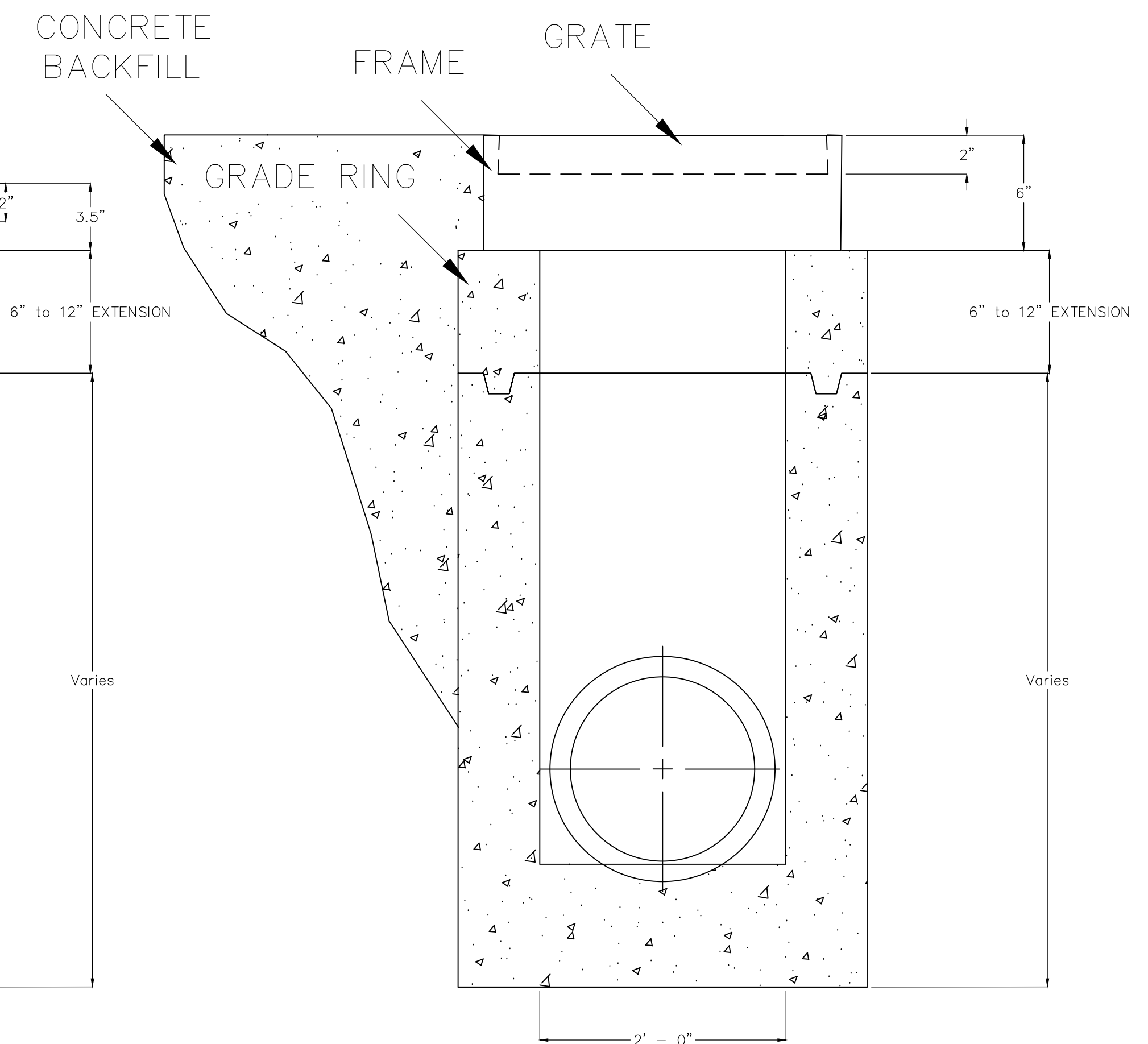

**PRECAST BOX SECTION CURB VIEW**

NOT TO SCALE

D  
2

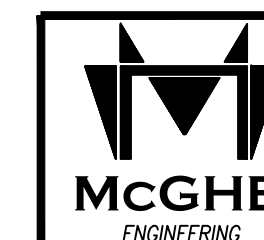

**MCGHEE ENGINEERING, INC.**

Phone: (270) 483-9985  
Fax: (270) 483-9986  
e-mail: mmcgee@apex.net

202 South Ewing Street  
P. O. Box 267  
Guthrie, Kentucky 42234

City of Pembroke  
222 S. Main St  
Pembroke, Kentucky 42266  
Phone: (270) 475-4343

Westbrooke Circle  
Drainage Grate Repair

Date	Prep. By	Scale	File No.	Sheet
10/2/2019	K. Willis	1" = 20'		2 of 2